

Synchronous Data Link Control

Concepts

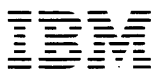
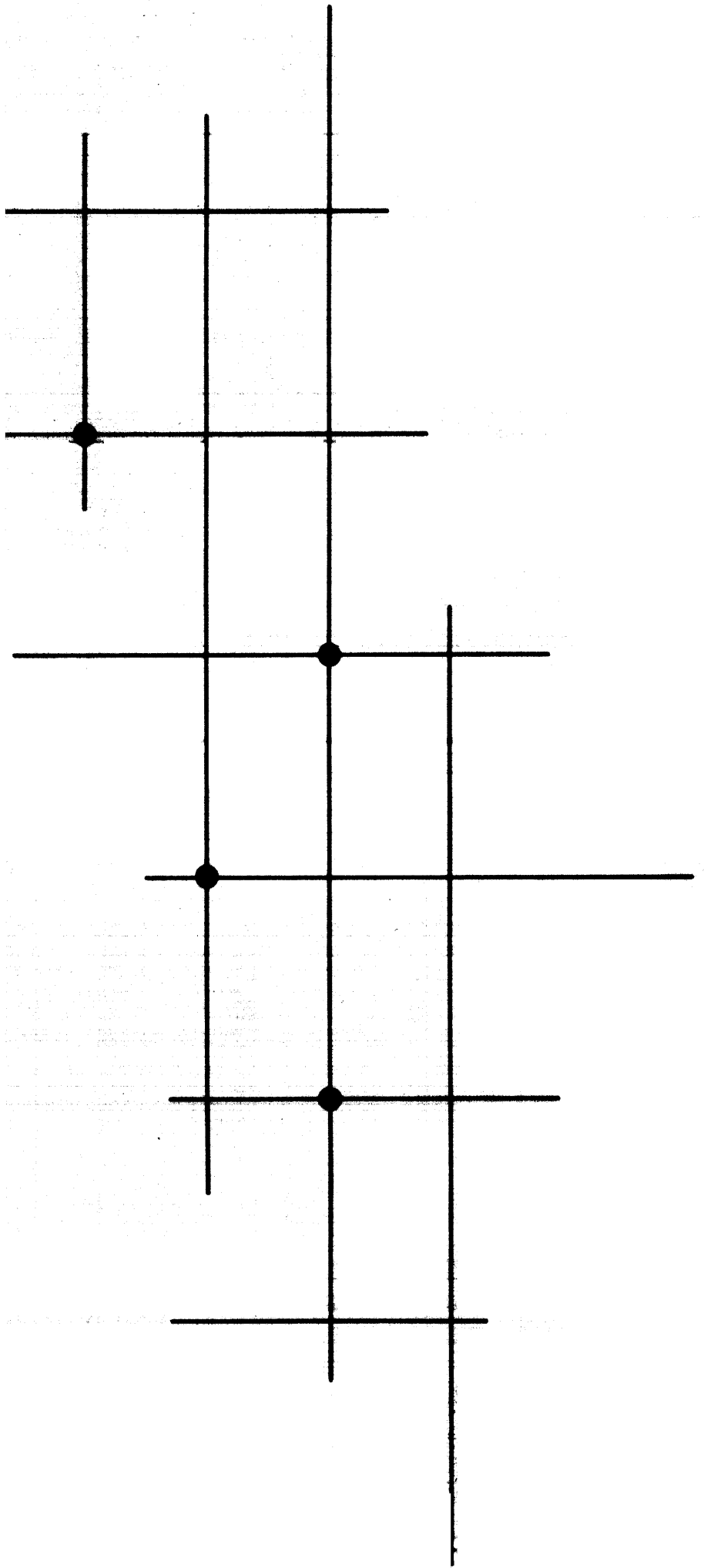

Synchronous Data Link Control

Concepts

Fourth Edition (June 1986)

This is a major revision of, and obsoletes, GA27-3093-2. New in this edition is information about modulo 128 operation, including a new command—SNRME (Set Normal Response Mode Extended). Changes related to modulo 128 operation are marked by a vertical line to the left of the change. This edition also includes other minor editorial changes and updates to terminology throughout; these changes are not marked by vertical lines. This edition omits the former Appendix C, "SDLC Commands and Responses: Acronym Update." The information it provided now appears in the present Appendix C (formerly Appendix D).

From time to time, changes are made to the information in IBM systems publications. Before using this publication in connection with the operation of IBM systems, consult your IBM representative or IBM branch office to find out which editions are applicable and current. For information pertaining to a specific IBM machine or system, refer to the appropriate IBM publication for that machine or system.

Publications are not stocked at the address given below: requests for IBM publications should be made to your IBM representative or to the IBM branch office serving your locality.

This manual has been written by the IBM Communication Products Division, Information Development, Department E02, P.O. Box 12195, Research Triangle Park, North Carolina 27709. A reader's comment form is provided at the back of this publication. If the form has been removed, comments may be sent to the above address. IBM may use or distribute any of the information you supply in any way it believes appropriate without incurring any obligation whatever. You may, of course, continue to use the information you supply.

Preface

This manual describes IBM Synchronous Data Link Control (SDLC). It includes a brief communications overview, a basic description to familiarize the reader with the terminology and concepts of SDLC, and some representative examples of the uses of SDLC.

Readers with no prior knowledge of data communication may wish to consider purchasing the materials for the self-study course entitled "Communication System Concepts," course number I0026. (This course may be ordered by calling IBM Direct at 1-800-IBM-2468. Additional information about IBM courses is given in the *IBM Catalog of IBM Education*, GE20-1244, available from your IBM representative or the IBM branch office serving your locality.)

Prerequisite Publication: Readers who are not familiar with IBM's Systems Network Architecture (SNA) should first read *Systems Network Architecture Concepts and Products*, GC30-3072.

A reader who is familiar with other data link control procedures should not assume that familiar terms have the same definitions in SDLC procedures, or that familiar functions have the same names. The *IBM Vocabulary for Data Processing, Telecommunications, and Office Systems*, GC20-1699, is a useful reference for the definitions of terms used in this manual.

This manual does not provide instructions for implementing SDLC, nor does it describe any specific equipment or programs that may be needed to implement SDLC. For specific information about an IBM SDLC implementation, refer to the appropriate IBM publication for that machine or system. For information on Systems Network Architecture (SNA), within which SDLC is a data link control, refer to *Systems Network Architecture Concepts and Products*, GC30-3072; *Systems Network Architecture Technical Overview*, GC30-3073; and *Systems Network Architecture Reference Summary*, GA27-3136.

This manual contains three chapters and three appendixes:

"Chapter 1. Introduction," contains general information on telecommunications and data link control.

"Chapter 2. Basic Concepts," presents the elementary information you need to understand SDLC.

"Chapter 3. Further Concepts, Applications, and Examples," presents additional concepts, defines the SDLC commands and responses, and

shows some applications and examples of the use of SDLC for specific link configurations.

Appendix A, "SDLC Frame Summary," contains the binary codes for SDLC commands and responses.

Appendix B, "SDLC Computation of the FCS Field," describes the operation of cyclic redundancy checking and its use in the SDLC frame check sequence.

Appendix C, "IBM SDLC and Data Link Control Standards," shows the relationship between SDLC and data link control standards and explains IBM's conformance to these standards.

A list of abbreviations and a glossary appear between Appendix C and the Index.

Contents

Chapter 1. Introduction

Data Links and Their Components	3
Configurations and Operating Characteristics	4
Half-Duplex and Duplex	6
Two-Way Alternate and Two-Way Simultaneous Link Station Operation	7
Signal Conversion	10
Data Link Control Activities	12
Bit Synchronization and Invert-on-Zero Coding	14

Chapter 2. Basic Concepts

Primary and Secondary Link Stations	19
Transmission States	19
Transient State	19
Idle State	20
Active State	21
Transmission Frames	21
Frame Format	22
Flags	23
Address Field	23
Control Field	24
Unnumbered (U) Format	25
Supervisory (S) Format	25
Information (I) Format	25
The P/F Bit	25
Information Field	25
Frame Check Sequence (FCS) Field	26
Frame Numbering	26
Zero Insertion	27
Time Outs	28
Idle Detect	29
Nonproductive Receive	30
Abort Conditions	30
Recovery from Errors and Special Conditions	31
Link-Level Recovery	31
Higher-Level Recovery	32

Chapter 3. Further Concepts, Applications, and Examples

Secondary-Station Mode Definitions	35
Initialization Mode	35
Normal Response Mode (NRM) and Normal Response Mode Extended (NRME)	35
Normal Disconnected Mode (NDM)	36
Command and Response Definitions	36

Unnumbered (U) Format	38
Supervisory (S) Format	41
Information (I) Format	42
SDLC on a Switched Link	42
SDLC in a Loop Configuration	42
Loop Operation	43
Primary Station Transmitting	43
Secondary Station Transmitting	44
Loop Commands	46
UP (Unnumbered Poll)	46
CFGR (Configure)	47
Loop Responses	49
BCN (Beacon)	49
CFGR (Configure)	49
Examples of SDLC Exchanges	51
Two-way Alternate Exchanges on Nonswitched Point-to-Point Links	52
Two-way Simultaneous Exchanges on Nonswitched Point-to-Point Links	54
Two-way Simultaneous Exchanges on Nonswitched Multipoint Links	56
Two-way Alternate Exchanges on Switched Point-to-Point Links	57
Two-Way Alternate Exchanges on SDLC Loops	58
Appendix A. SDLC Frame Summary	63
Appendix B. SDLC Computation of the FCS Field	65
Appendix C. IBM SDLC and Data Link Control Standards	69
List of Abbreviations	77
Glossary	79
index	83

Figures

1.	Components of a Data Link	3
2.	Channels and Transmission Media	4
3.	Link Connection Configurations	5
4.	Link Connection Configurations and Link Station Operation	8
5.	Data Conversion for Data Link Transfer	11
6.	Some Data Link Control Activities	13
7.	Discrete Transmission Coding	15
8.	Invert-on-Zero Transmission Coding	15
9.	Period of the Transient State	20
10.	Period of the Active State	21
11.	SDLC Transmission Frame	22
12.	Fields of the SDLC Transmission Frame, As Transmitted	23
13.	SDLC Frame: Control Field	24
14.	Example of Modulo-8 Frame Numbering	27
15.	Zero Insertion and Deletion	28
16.	Examples of Telecommunication Facilities	30
17.	Transmitting Station Aborts Transmission	31
18.	Summary of Command and Response C Fields	37
19.	Information Field of the FRMR Response	41
20.	Loop Configuration	43
21.	SDLC Loop Exchanges: Primary Station Transmitting	44
22.	SDLC Loop Exchanges: Secondary Stations Transmitting	46
23.	Format of Examples of SDLC Exchanges	51
24.	Two-way Alternate Exchanges on Nonswitched Point-to-Point Links	52
25.	Two-way Simultaneous Exchanges on Nonswitched Point-to-Point Links	54
26.	Two-way Simultaneous Exchanges on Nonswitched Multipoint Links	56
27.	Two-way Alternate Exchanges on Switched Point-to-Point Links	57
28.	Two-Way Alternate Exchanges on SDLC Loops	58
29.	SDLC Frames, As Transmitted	63
30.	An Example of Cyclic Redundancy Checking	66
31.	CRC Operation with SDLC	67
32.	HDLC Unbalanced Normal Class of Procedures	72
33.	HDLC Commands and Responses	73

Chapter 1. Introduction

This chapter introduces the various link configurations with which SDLC can be used and describes some of their operating characteristics.

Contents

Data Links and Their Components	3
Configurations and Operating Characteristics	4
Half-Duplex and Duplex	6
Two-Way Alternate and Two-Way Simultaneous Link Station Operation	7
Signal Conversion	10
Data Link Control Activities	12
Bit Synchronization and Invert-on-Zero Coding	14

Synchronous Data Link Control (SDLC) is a discipline for managing synchronous, code-transparent, serial-by-bit information transfer between nodes that are joined by data links. Data may be sent simultaneously in both directions (referred to as *two-way simultaneous* transmission) or alternately, in one direction at a time (referred to as *two-way alternate* transmission).

The link connection may have a point-to-point, multipoint, or loop configuration; a point-to-point link may be nonswitched or switched. SDLC includes comprehensive detection and recovery procedures for transmission errors that may be introduced onto the link.

Readers who are familiar with the concepts of information transfer over the various link configurations may skip to "Chapter 2. Basic Concepts." Other readers should continue reading here or refer to the preface of this manual for reading references.

Data Links and Their Components

This book uses the term *data link* and a number of related terms whose relationship is described in the next paragraphs. (The terms are defined fully in the Glossary at the back of this book.) Figure 1 shows the relationship graphically.

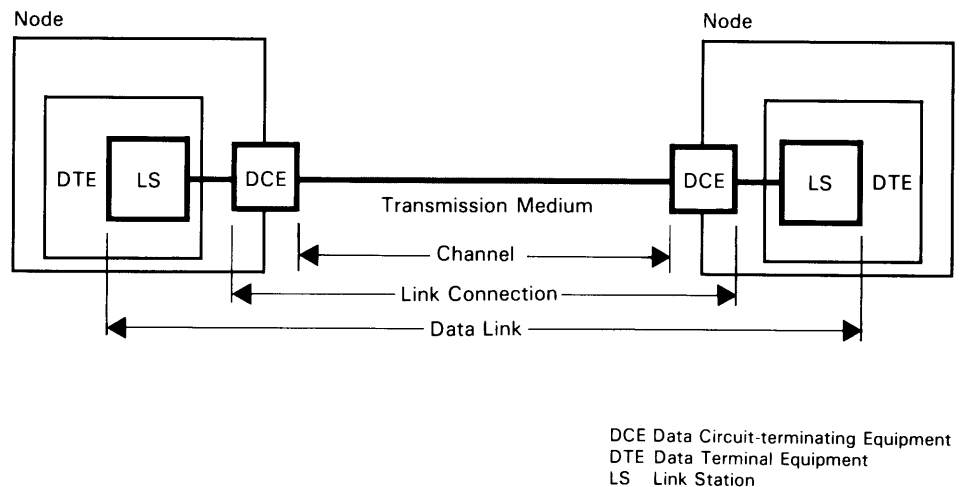

Figure 1. Components of a Data Link

Each SNA node that communicates with another SNA node over transmission media (such as telephone wires, microwave beams, fiber optic links, or satellite links, or combinations of these media) requires a link station and data circuit-terminating equipment (DCE).

A *link station* is the hardware and software that allows a node to attach to and provide control for a link. The link station is part of the *data terminal equipment (DTE)*—the general term for equipment, such as processors, controllers, and terminals, that communicate over data links.

Data circuit-terminating equipment (DCE) is the equipment used to establish, maintain, and terminate a connection, and to provide appropriate modulation

of the business-machine signal for transmission on a telecommunication facility, and vice versa. The function of the DCE is separate from that of the DTE and is therefore shown separately in Figure 1, but it may be part of the same physical package as the DTE. The part of the data link that includes the DCEs and the channel between them, but not the link stations, is called the *link connection*. (Another term for link connection is *data circuit*.)

A data link consists of (1) the link stations at the SNA nodes it connects, (2) the DCEs associated with each link station, and (3) the channel that connects the DCEs together. In this book the term *channel* refers to the path provided by the transmission media that a link connection uses; the channel includes whatever signal conversion equipment is necessary to transfer data from one transmission medium to another within the channel. In this context, a channel is bidirectional—that is, it can transfer data in both directions.

Although Figure 1 and other figures in this book show a link connection and its channel extending over only one transmission medium, in practice they sometimes encompass more than one medium. Figure 2 shows an example in which the channel between a pair of DCEs uses both wires and optical fibers as transmission media. This figure also shows that the same transmission media may provide a number of separate channels.

Figure 1 shows a point-to-point configuration joining two SNA nodes; as described shortly, multipoint configurations can be used as well.

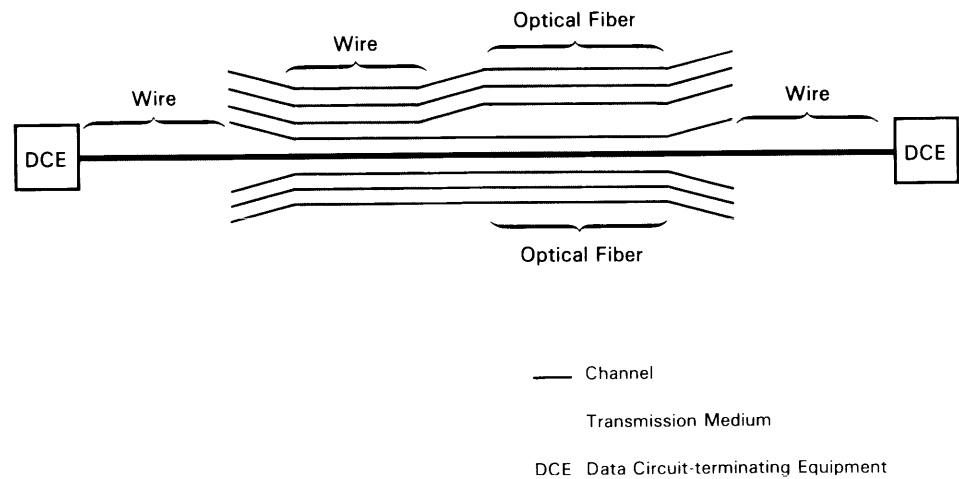

Figure 2. Channels and Transmission Media

Configurations and Operating Characteristics

The remainder of this chapter explains the various link connection and data link configurations for which SDLC can be used, and mentions some operating characteristics related to each.

A link connection can have one of the following basic configurations, as shown in Figure 3:

- Nonswitched point-to-point
- Switched point-to-point
- Nonswitched multipoint
- Loop.

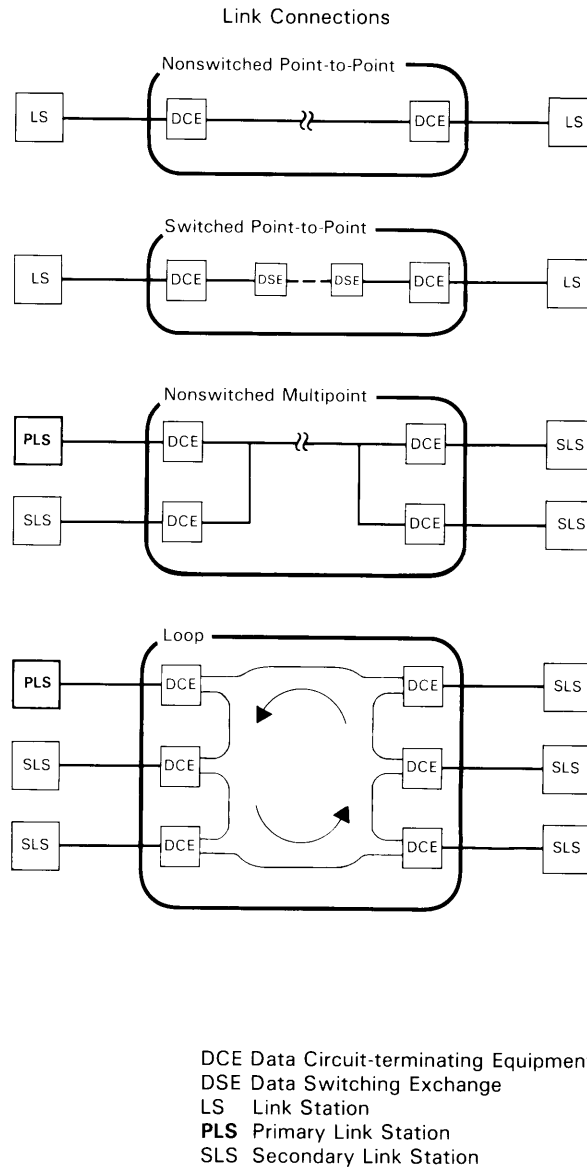

Figure 3. Link Connection Configurations

In a nonswitched configuration, the link connection exists for a period of time independent of whether it is being used to transmit data. This period of time may be continuous—that is, 24 hours a day, seven days a week—as when the user owns the facilities used or contracts with a public data network for the facilities. Alternatively, the duration may be shorter, as when the user contracts for the facilities to be available eight hours a day, five days a week.

In either case, if the facilities are contracted for rather than owned, the channels and transmission media used by the link connection may vary from time to time, even though nonswitched link connections are sometimes

referred to as “permanent” to distinguish them from temporary, switched link connections.

In a switched configuration, a connection is established each time there is data to be transmitted, and the connection is broken after transmission is completed. Each time a switched connection is established it is likely to use a different combination of channels and transmission media.

A point-to-point configuration has two link stations; a multipoint configuration has three or more link stations. One link station on a multipoint link is called the *primary link station*; it controls use of the link by all the link stations attached to it. The rest of the link stations on the link are called *secondary link stations*. Chapter 2 describes the differences between primary and secondary link stations in more detail.

In a multipoint configuration, the secondary link stations communicate only with the primary link station—never with each other. The primary and each secondary form a pair logically distinct from each other pair; thus, each pair can be viewed as comprising a single point-to-point link sharing the same multipoint configuration with other point-to-point links. Only the primary link station, in its scheduling of the shared configuration, is aware of the multiple use of the common connection. The term *link* can then be applied to each pair of communicating link stations, independent of the underlying configuration.

Half-Duplex and Duplex

In all but the loop configuration, data and control signals can flow in either direction over the link connection. Whether they can flow simultaneously in both directions, or in only one direction at a time, depends on the equipment (such as amplifiers) in the channel, upon the data circuit-terminating equipment (DCE) in the link connection, and upon the link station that uses the link connection.

The term *duplex* refers to the capability of the channel and the link connection to transfer data in both directions at once. The term *half-duplex* refers to the capability of the channel and the link connection to transfer data in both directions, but *not* at the same time.

To the basic non-loop configurations listed above, the qualifiers *duplex* and *half-duplex* can be applied. The possible configurations are then:

- Half-duplex, nonswitched point-to-point
- Duplex, nonswitched point-to-point
- Half-duplex, switched point-to-point
- Duplex, switched point-to-point
- Half-duplex, nonswitched multipoint
- Duplex, nonswitched multipoint.

Two-Way Alternate and Two-Way Simultaneous Link Station Operation

If either the channel or the DCE is capable only of half-duplex operation, then the link stations on the link must send and receive data alternately—this is called *two-way alternate* transmission. If the channel and the DCE are both capable of duplex operation, then the link stations may send and receive data simultaneously—this is called *two-way simultaneous* transmission. Or they may send and receive data alternately, as for half-duplex operation.

Figure 4 shows the possible variations of link station operation for each of the link connection configurations shown in Figure 3. The configurations in this figure are labeled A through K.

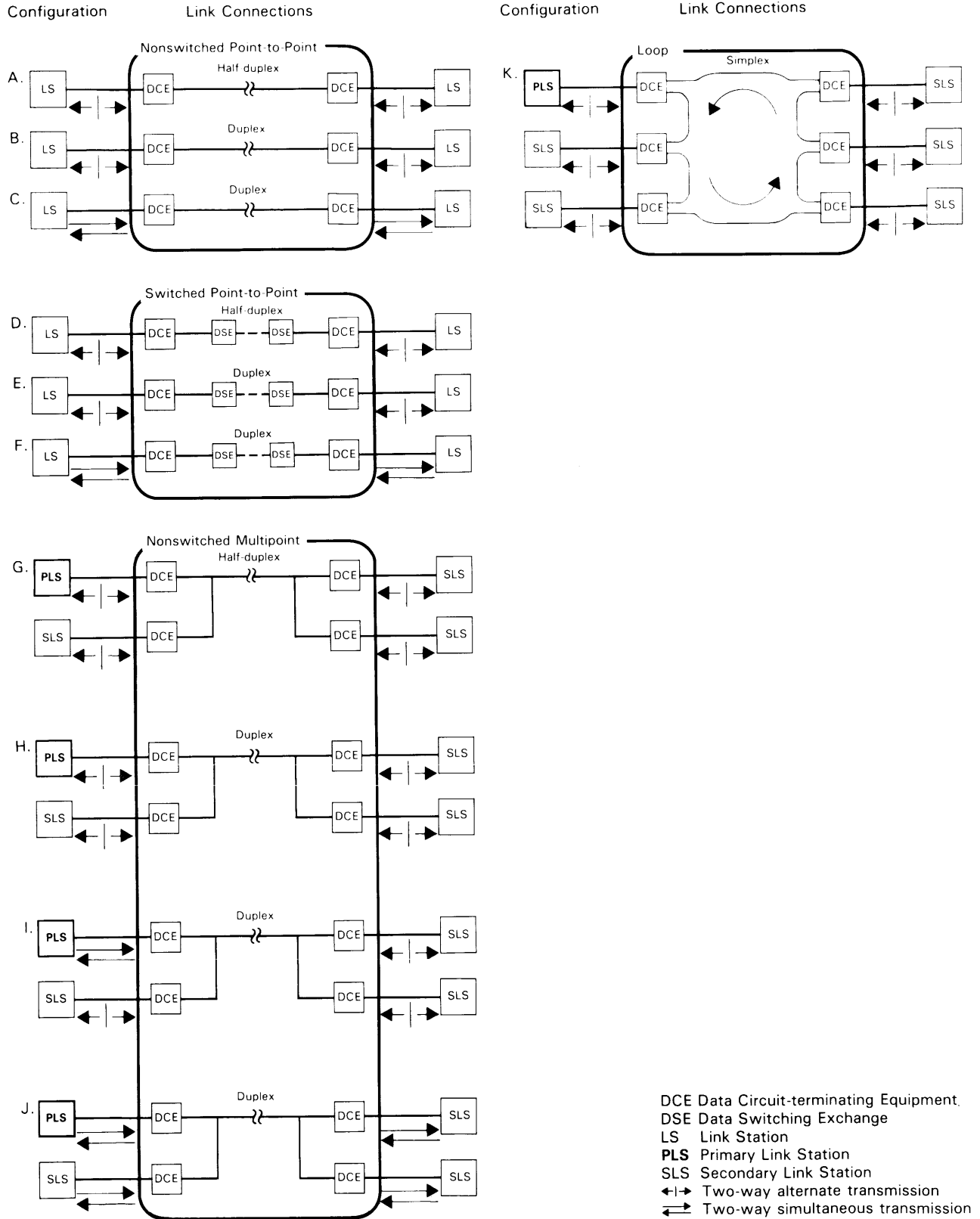

Figure 4. Link Connection Configurations and Link Station Operation

Configurations A, B, and C are nonswitched point to point. Configuration A is half duplex and therefore allows only two-way alternate transmission. A duplex configuration can accommodate either two-way alternate or two-way simultaneous transmission, as shown in configurations B and C, respectively.

Configurations D, E, and F are switched point-to-point configurations. Configuration D is half duplex and therefore allows only two-way alternate transmission. A duplex configuration can accommodate either two-way alternate or two-way simultaneous transmission, as shown in configurations E and F, respectively.

Configurations D, E, and F are equivalent in data link operation to configurations A, B, and C, respectively; they differ only in that they use switched rather than nonswitched link connections. After a switched link connection is established, data link operation is the same as for nonswitched connections.

Configurations G through J are nonswitched multipoint. The link connection in configuration G is half duplex and therefore allows only two-way alternate transmission. The link connections in configurations H through J are duplex, but link station operation differs for these three configurations, as follows.

In configuration H, transmission is two-way alternate for the primary link station and for each secondary link station.

In configuration I, the primary link station can send to one of the secondary link stations while at the same time receiving from another secondary link station. Transmission is thus two-way simultaneous for the primary link station but two-way alternate for the secondary link stations.

In configuration J, the primary link station can send to and receive from the same secondary link station at the same time. Each secondary link station in this configuration can thus simultaneously send to and receive from the primary station, but only one of them at a time can do so.

The term *duplex-multipoint operation* is sometimes applied to configurations I and J.

In configuration K, the link connection is a loop. Although transmission on the loop is always in the same direction (referred to as *simplex* transmission), logically all the link stations use two-way alternate transmission.

In all of the configurations of Figure 4, the choice of two-way simultaneous or two-way alternate transmission is determined for each link station through control program parameters specified at the time the network is configured.

(Loop configurations are not further considered until Chapter 3, under "SDLC in a Loop Configuration" on page 42.)

Signal Conversion

When analog telecommunication facilities are used for data links, the binary digital information that is characteristic of information processing machines must be converted to a form similar to that used for transmitting speech signals. Two fundamental conversions are necessary, as shown in Figure 5:

- All data and control information are converted (*serialized*) to a serial stream of binary digits (0's and 1's). Data terminal equipment (DTE) makes this conversion.
- The binary signals are made compatible with analog transmission equipment by data circuit-terminating equipment (DCE).

Receiving equipment reverses both processes: binary information is recovered from received signals by DCE, and is then regrouped (*deserialized*) by DTE into the original data and control information.

Figure 5. Data Conversion for Data Link Transfer

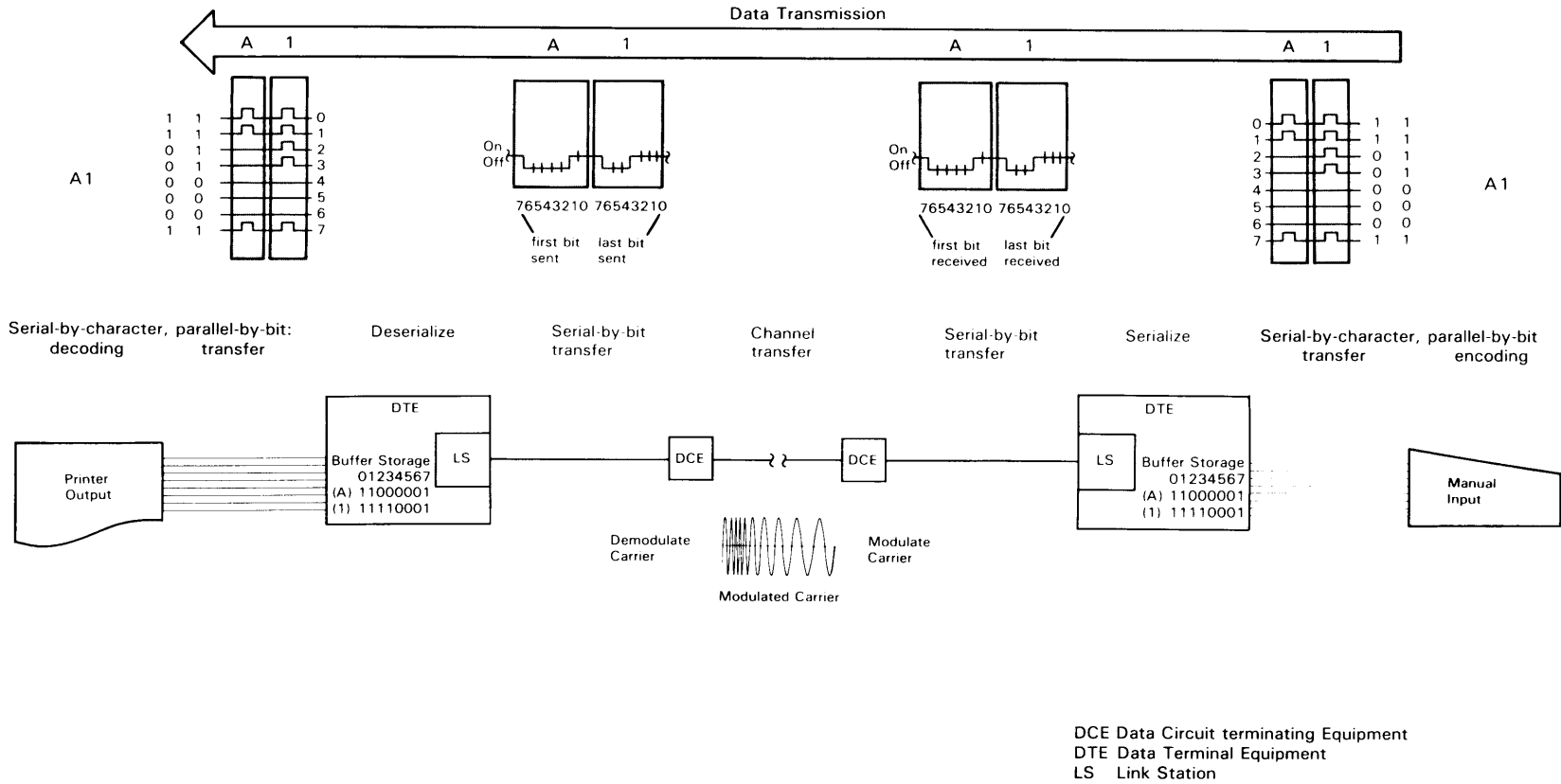

Data Link Control Activities

The actual transfer of data requires nondata transmissions for setting up, controlling, checking, and terminating the information exchange. Such transmissions are a part of data link control. (System control information, such as input/output device controls, is not considered data link control information.)

The following are data link control activities (see Figure 6):

- Synchronizing—getting the receiver in bit synchronism and character synchronism with the transmitter
- Detecting and recovering from transmission errors
- Controlling send/receive—using a primary station to manage each data link (others are secondary stations)
- Reporting unacceptable conditions such as buffer overrun at the receiver.

Data link control keeps transmitter and receiver synchronized:

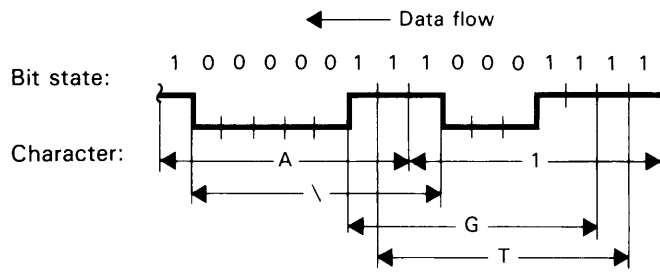

The receiver and the transmitter must be in bit and character synchronism (lack of synchronism results in inability of receiver to determine if incoming character is A, \ , G, or T).

Data link control detects transmission errors:

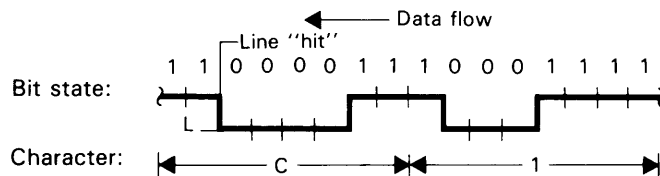

A single binary digit is changed by a transmission error. The receiver must recognize that the error has occurred.

Data link control coordinates sending and receiving:

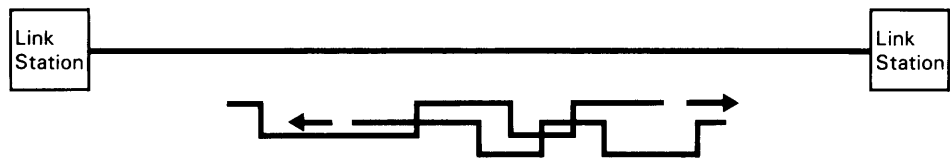

When one station transmits, the other station must receive; otherwise, no communication occurs.

Data link control handles exception conditions:

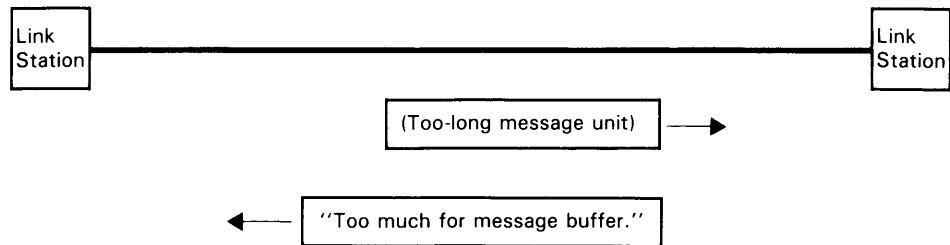

Figure 6. Some Data Link Control Activities

Bit Synchronization and Invert-on-Zero Coding

A synchronous transmission is time based to enable the DCE or DTE to identify the sequential binary digits (see Figure 7). SDLC procedures assume that bit synchronization is provided by either the DCE or the DTE.

A receiving DTE or DCE samples the value of the incoming signal at the same rate the transmitting DCE used to transmit the signal. There may be minor variations in timing between transmitter and receiver, however, that make it necessary for the receiver to dynamically adjust sample timing to keep sample times midway between bit transitions. DCEs that provide received-data timing to the DTE perform this function.

If the DCE does not provide received-data timing, the DTE must provide and adjust the sample timing. In this case, an *invert-on-zero* transmission coding method (also known as NRZI, *non-return to zero inverted*) is used, in which the DTE holds the signal condition in the same state to send a binary 1. To send a binary 0, the DTE changes the signal condition to the opposite state (see Figure 8). Thus, the long periods of binary 0 data that sometimes occur have successive transitions in the transmitted bit stream. (*Zero insertion*, a characteristic of SDLC procedures that is explained in Chapter 2, creates transitions when extended periods of binary 1 transmission occur.) Invert-on-zero transmission coding, if used on a link, must be used by all DTEs attached to the link.

SDLC is a bit-oriented procedure and any receiving error invalidates the segment of the transmission that contains the error; so it is important that bit synchronism be maintained. When DCEs do not provide received-data timing, the DTE must provide invert-on-zero transmission coding to reduce the probability of losing bit synchronism. Invert-on-zero coding may be required for certain DCEs that have specific bit-pattern sensitivities. Invert-on-zero coding may be prohibited for other DCEs that have different bit-pattern sensitivities.

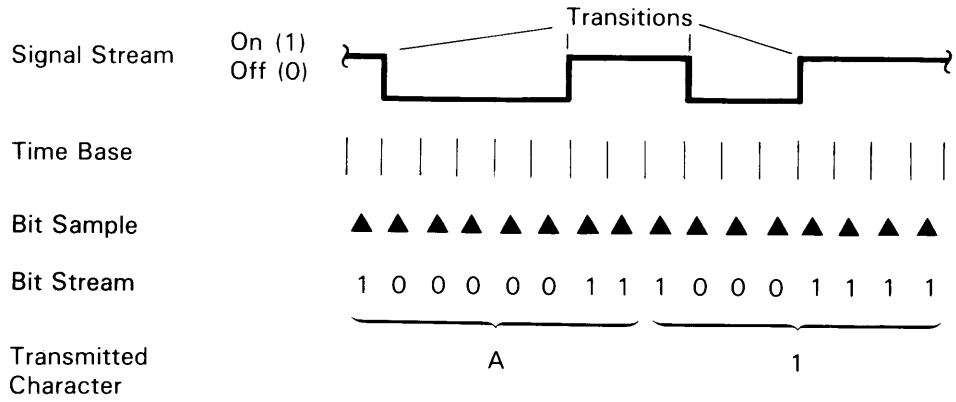

Figure 7. Discrete Transmission Coding

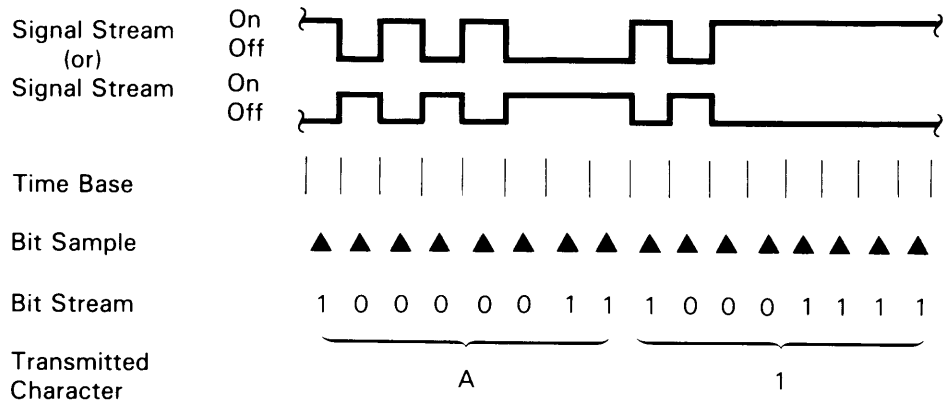

Figure 8. Invert-on-Zero Transmission Coding

Chapter 2. Basic Concepts

This chapter describes some basic concepts of SDLC and explains some SDLC procedures that help in recovery from transmission errors.

Contents

Primary and Secondary Link Stations	19
Transmission States	19
Transient State	19
Idle State	20
Active State	21
Transmission Frames	21
Frame Format	22
Flags	23
Address Field	23
Control Field	24
Unnumbered (U) Format	25
Supervisory (S) Format	25
Information (I) Format	25
The P/F Bit	25
Information Field	25
Frame Check Sequence (FCS) Field	26
Frame Numbering	26
Zero Insertion	27
Time Outs	28
Idle Detect	29
Nonproductive Receive	30
Abort Conditions	30
Recovery from Errors and Special Conditions	31
Link-Level Recovery	31
Higher-Level Recovery	32

Four concepts are fundamental to an understanding of SDLC:

- The definitions and responsibilities of primary and secondary link stations
- The definitions of the transmission states that affect information transfer
- How information is formatted into transmission frames
- How transmission frames are organized into larger sequences.

Primary and Secondary Link Stations

A *link station* comprises procedures and control information that coordinate the transfer of data between two nodes joined by a link connection.

A primary link station has the responsibility for controlling a data link; it issues commands. Secondary link stations receive commands from the primary link station and return responses to it. Each transmission on a link connection is from the primary station to one or more secondary stations, or from a secondary station to the primary station.

Transmission States

A link connection can be in one of three states:

- Transient state
- Idle state
- Active state.

A link connection can be in only one of these states at a time.

Transient State

The *transient state* exists when the link connection is being conditioned before initial transmission and after each transmit-receive reversal (or *turnaround*); see Figure 9.

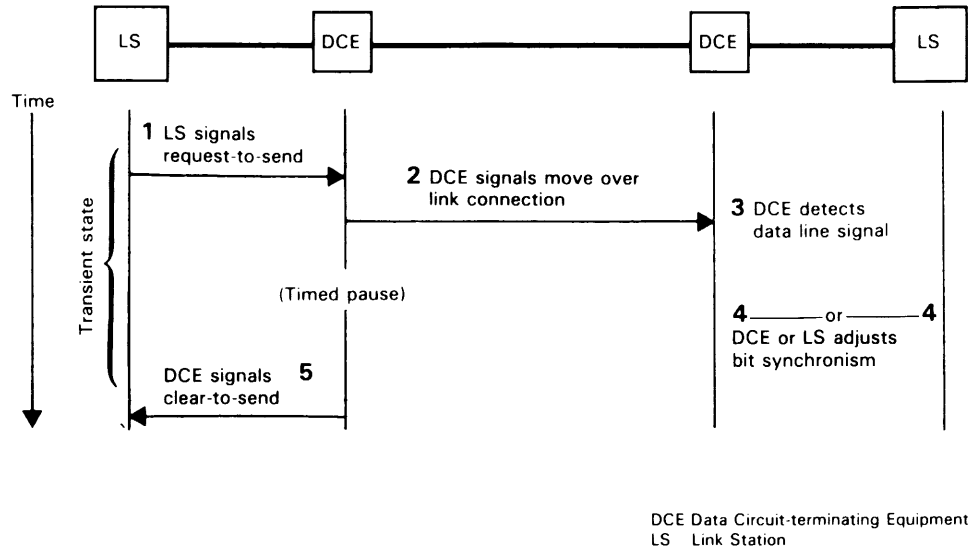

Figure 9. Period of the Transient State

Idle State

When a link connection is operational, but no SDLC control or information is currently being transmitted, it is in the *idle state*.

A link station detects the existence of the idle state when, after receiving an *idle pattern*—a succession of 15 consecutive binary 1's—it continues to receive binary 1's.

Note: A station that is not transmitting SDLC control or information data may, nevertheless, send signals onto the link connection.

The link connection configuration used determines the appropriate link station action in the idle state, as follows:

<i>Link Connection</i>	<i>Primary Link Station</i>	<i>Secondary Link Station</i>
Half-duplex point-to-point	Carrier off	Carrier off
Duplex point-to-point	All 1's	All 1's
Half-duplex multipoint	Carrier off	Carrier off
Duplex multipoint	All 1's	Carrier off

Active State

A link connection is in the *active state* when a link station is transmitting or receiving either information or data link control signals (via transmission frames described in the next section, "Transmission Frames"). The active transmission state is the nonidle, nontransient state. The link connection is also in the active state when a series of flags (also described in the next section) is being transmitted. In this case no information is exchanged, but the link connection is held in the active state (see Figure 10). A duplex link connection may be active in one direction and idle in the other.

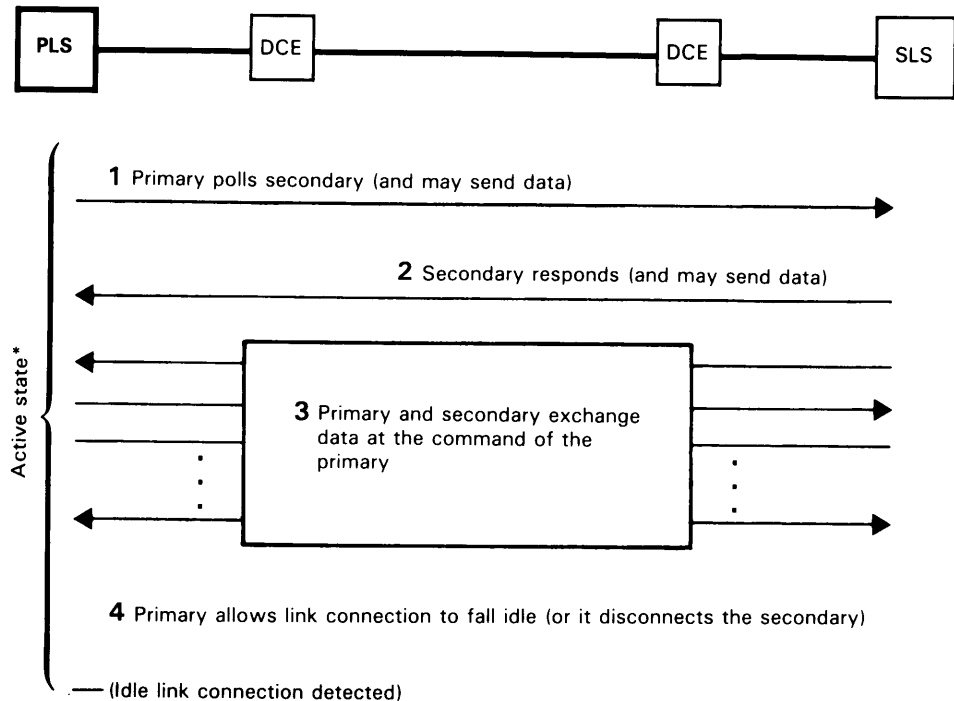

*A half-duplex link connection is in transient state during each line turnaround

Figure 10. Period of the Active State

Transmission Frames

All data and control transmissions on an SDLC data link are organized in a specific format called a *transmission frame*—also called *SDLC frame*, or simply *frame* (see Figure 11). This format carries control information and user data between a transmitting station and a receiving station and allows a receiving station:

- To determine where the frame starts and ends.
- To determine whether the frame is intended for that station
- To determine what actions to perform with the information received

- To detect the occurrence of transmission errors in received frames
- To acknowledge its receipt of frames to the transmitting station.

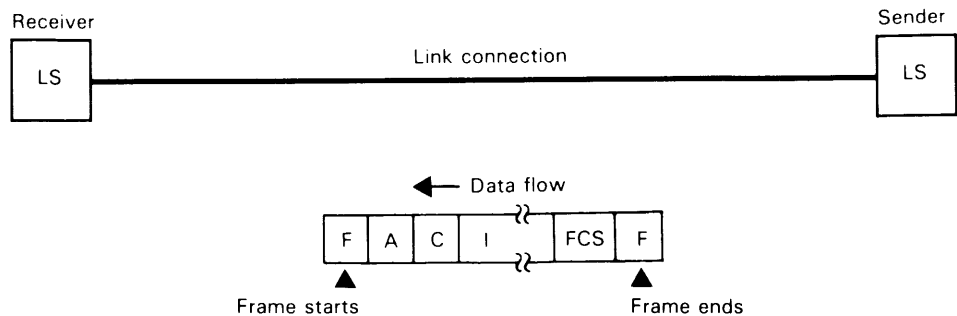

Figure 11. SDLC Transmission Frame

Frame Format

Each SDLC transmission frame has the same specific format. Each frame is made up of:

- A beginning flag (F) that marks the beginning of the frame
- An address (A) field that identifies the secondary station that is sending (or is to receive) the frame
- A control (C) field that specifies the function of the particular frame
- An optional information field that contains information data
- A frame check sequence (FCS) field that allows the receiving station to check the transmission accuracy of the frame
- An ending flag (F) that signals the end of the frame.

Each of these fields contains either 8 bits or a multiple of 8 bits (see Figure 12).

This figure shows the bit sequence in the frame as transmitted over the link connection. All fields except the frame check sequence are transmitted low-order bit first. The leftmost bit in each field shown in Figure 12, except the FCS field, is the *low-order* bit of that field. The leftmost bit of the FCS field is the *high-order* bit (most significant bit) of the FCS field.

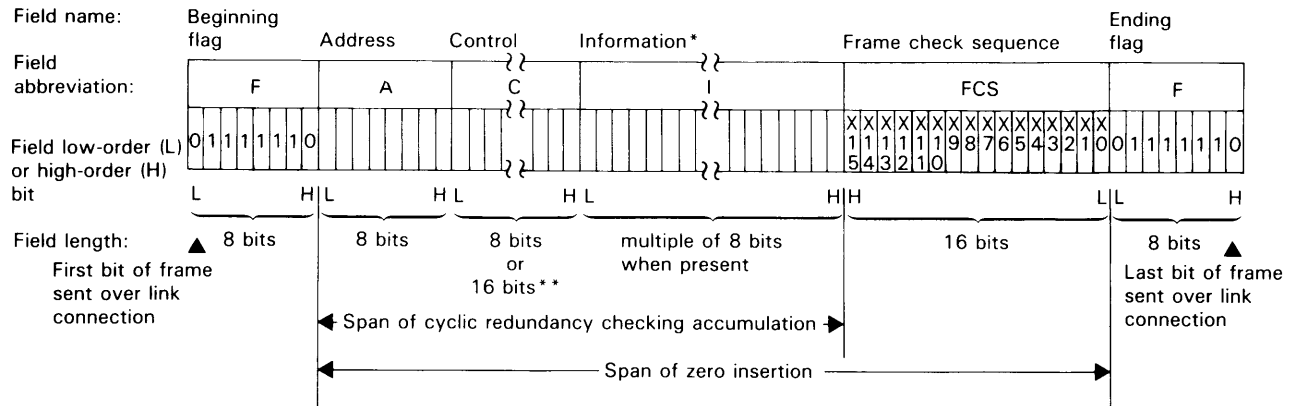

* Optional, variable length
 ** 8 bits for modulo-8 operation, 16 bits for modulo-128 operation

Figure 12. Fields of the SDLC Transmission Frame, As Transmitted

Flags

The beginning flag and the ending flag enclose the SDLC frame. The beginning flag serves as a reference for the position of the A (address) and C (control) fields and initiates transmission error checking; the ending flag delimits the end of the FCS field and marks the end of the frame.

Both beginning and ending flags have the binary format 01111110. The ending flag for one frame may serve as the beginning flag for the next frame. Alternatively, the ending 0 of an ending flag may serve as the beginning 0 of a beginning flag, thus forming the pattern 011111101111110. Also, the transmitting link station inserts multiple flags between frames to maintain the active state if time fill is required. Zero insertion, described under "Zero Insertion" on page 27, prevents the flag pattern from occurring anywhere else in the frame.

Any ending flag may be followed by a frame, by another flag, or by an idle condition.

Address Field

The address field of an SDLC frame follows immediately after the beginning flag. It serves the same purpose as the address or return address on a letter mailed through the post office. The address that is sent is always the address of the secondary station on the link connection. If the primary station is transmitting the frame, the address is similar to the main address on a letter—it tells where the message is to go. If a secondary station is transmitting the frame, the address is similar to the return address on a letter—it tells where the message originated.

For application purposes, it may be useful to have special addresses specified that direct frames to a number of stations or to all the stations on the link connection. In this case, a secondary station may have three types of address:

- Its own individual address: a *station address*.
- An address that is common to a number of stations: a *group address*.
- An address that all stations on the link connection will accept: a *broadcast address* (sometimes called an *all-stations address*). An address field of all 1's is reserved for use solely as the broadcast address.

Note: An all-0's address field is reserved as a "no station's address"; therefore, no secondary station is assigned this as one of its addresses.

Control Field

The control field (C field) follows the address field. The control field defines the function of the frame and can be in one of the three formats shown in Figure 13: *unnumbered (U) format*, *supervisory (S) format*, or *information (I) format*. (The corresponding frame is similarly named.)

The control field bits shown as "Code" in the figure represent the SDLC command or response indicated by the frame. The commands and responses are explained in "Command and Response Definitions" on page 36, and are summarized in Appendix A.

Supervisory Format

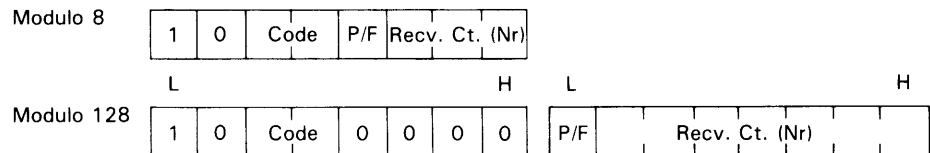

Information Format

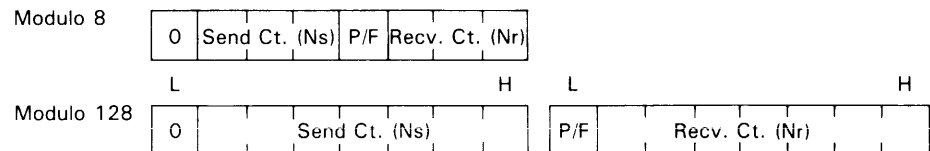

Unnumbered Format

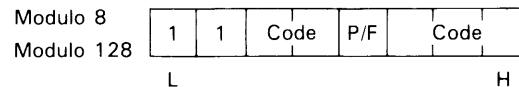

L Low-order bit (first bit in each byte transmitted)
H High-order bit (last bit in each byte transmitted)

Figure 13. SDLC Frame: Control Field

Unnumbered (U) Format

Unnumbered frames are used for such functions as:

- Establishing and disconnecting the data link
- Reporting certain procedural errors
- Transferring data (when the location of the data in a sequence of frames is not to be checked).

Supervisory (S) Format

Supervisory frames assist in the transfer of information, though they do not carry information themselves. They are used to acknowledge received frames, to convey ready or busy conditions, and to report frame numbering errors (indicating that a numbered information frame was received out of its proper sequence).

Information (I) Format

Information frames transfer information. Besides indicating the format, the control field contains send and receive counts (*Ns* and *Nr*). SDLC procedures use the *Ns* count to ensure that these frames are received in their proper order; they use the *Nr* count to confirm that received information frames are accepted.

The *Ns* count indicates the number of the information frame within the sequence of information frames transmitted. The *Nr* count transmitted in a frame is the number (*Ns*) of the information frame that the station transmitting the *Nr* count expects to receive next. "Frame Numbering" on page 26 gives more details about this process.

Note: The *Ns* count is present only in a control (C) field of the information format. An *Nr* count appears in C fields of information and supervisory frames. Neither the *Nr* nor the *Ns* count is present in a C field of unnumbered frames.

The P/F Bit

All three C field formats contain a poll/final (P/F) bit. A P (poll) bit is sent to a secondary station to require that it initiate transmission; an F (final) bit is sent to a primary station by a secondary station in the last frame of a transmission. (Do not confuse the F (final) bit with the F (flag) frame delimiter pattern.) Only one P bit may be outstanding (unanswered by an F bit) at one time on any of the data links described thus far.

Information Field

Following the control field, there may or may not be an information field. The supervisory frame does not contain an information field.

Data to be transferred on the data link is contained in the information field of a frame. The information field does not have a set length, but must be a multiple of 8 bits. In each 8-bit grouping (octet), the low-order bit is sent first and the high-order bit is sent last.

Frame Check Sequence (FCS) Field

Following the information field (or control field if no information field is present) is the frame check sequence (FCS) field. The purpose of this field is to check the received frame for errors that may have been introduced by the link connection. This field contains a 16-bit check sequence that is the result of a computation on the contents of the A, C, and information fields at the transmitter. The computation method used is called *cyclic redundancy checking* (CRC).

The receiver makes a similar computation on the received frame. If the frame is received with an error, the receiver rejects the frame and discards it. Thus, the receiver accepts no frame that it finds to be in error.

The FCS field is followed by the ending flag, closing the frame.

See Appendix B, "SDLC Computation of the FCS Field," for more details on the FCS field and on CRC.

Frame Numbering

A station that is transmitting numbered information frames numbers each one by placing its number in the Ns count field of the frame. The receiving station checks this number to determine if any frames are missing or duplicated.

A station that is receiving numbered information frames accepts each one that is error free and in sequence and advances its receive count (Nr) for each such frame. If the received frame is error free, a receiving station's Nr count is the same as the Ns count that it will receive in the next numbered information frame—that is, a count of 1 greater than the Ns count of the last frame accepted. The receiver confirms its acceptance of numbered information frames by returning its Nr count to the transmitting station.

The Nr count at the receiving station advances when the station checks the frame and finds it to be error free and in sequence; Nr then becomes the count of the "next-expected" frame and should agree with the next incoming Ns count. If the incoming Ns count does not agree with the Nr count, the frame is out of sequence and Nr does not advance. The receiver does not accept out-of-sequence frames. It does, however, accept the incoming Nr count (for confirmation purposes) if the out-of-sequence frame is otherwise error free.

The counting capacity for Nr and Ns is 8, using the numbers 0 through 7 (for modulo-8 operation); or 128, using the numbers 0 through 127 (for modulo-128 operation). These counts "wrap around"; that is, 7 (or 127) is sequentially followed by 0. Up to seven (or 127) unconfirmed, numbered information frames may be outstanding (transmitted but not confirmed) at the transmitter.

The restriction that, at most, modulus-minus-1 frames (that is, 7 or 127 frames) may be outstanding at any time prevents ambiguity when error recovery results in retransmissions. For example, if eight frames (numbered 0 through 7) were transmitted and a response were returned with an Nr count

of 0, the transmitter could not determine whether the response confirmed the most recent 1 frames 0 through 7 or indicated that retransmission was required.

All unconfirmed frames must be retained by the transmitter, because some or all of them may have to be retransmitted if transmission errors or buffering constraints occur. The reported *Nr* count is the number of the next frame that the receiver expects to receive, so if, at a checkpoint, the *Nr* count is not the same as the transmitter's next frame (*Ns*) number, some of the frames already sent must be retransmitted. (See Figure 14 for an example of modulo-8 frame numbering.)

The *Nr* and *Ns* counts of both stations are initialized to 0 by control of the primary station. At other times, the counts advance as numbered frames are sent and received.

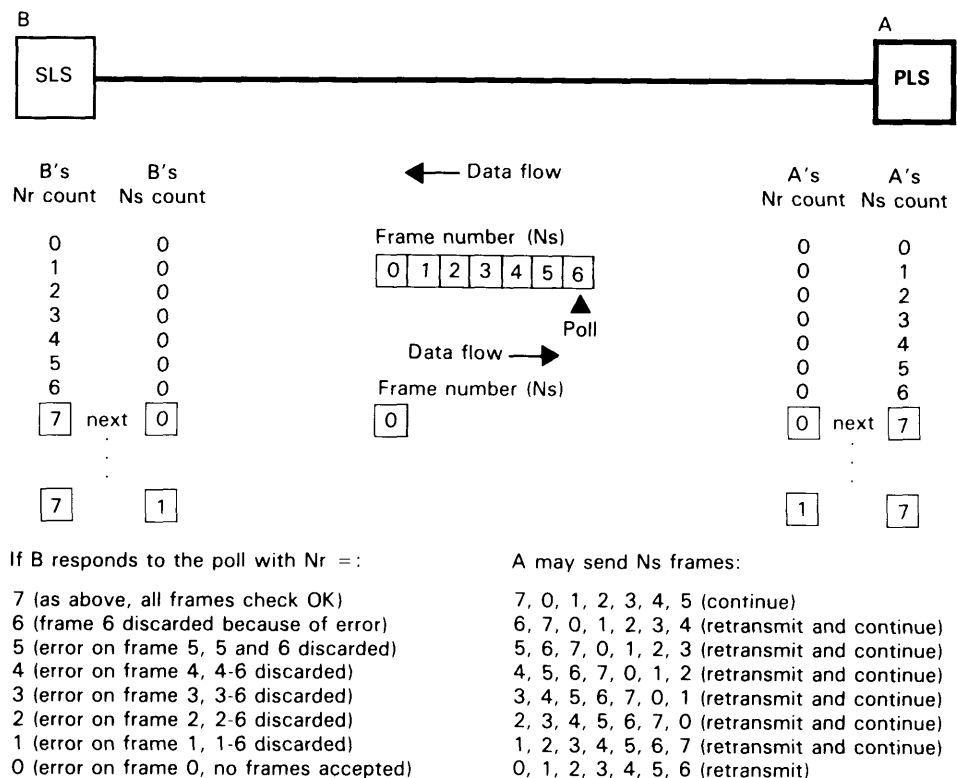

Figure 14. Example of Modulo-8 Frame Numbering

Zero Insertion

A frame is identifiable because it begins and ends with a flag and contains only nonflag bit patterns between the flags. This characteristic does not restrict the contents of a frame because SDLC procedures require that the transmitter insert a binary 0 after any succession of five contiguous 1's within the frame. (This action is sometimes called "bit stuffing.") Thus, no pattern of 01111110 (a flag) is ever transmitted between the beginning and ending flags.

Zero-bit insertion is disabled when the flag is being transmitted. After testing for flag recognition, the receiver removes a 0 that follows five contiguous 1's (see Figure 15). A 1 that follows five contiguous 1's is not removed; it signifies a frame abort (if it is followed by one or more 1's) or the arrival of a flag (if it is followed by a 0). Inserted and removed 0's are not included in the frame check sequence computation.

Note: When invert-on-zero transmission coding is used, zero insertion eliminates the remaining possibility of prolonged transitionless periods (continuous 1 bits) in the active state (see "Bit Synchronization and Invert-on-Zero Coding" on page 14).

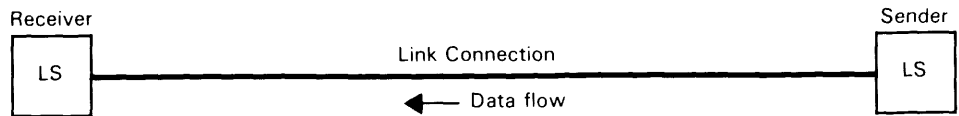

- Recognize flags
- Delete a 0 after each five 1's between flags
- Check for transmission errors
- Deserialize characters

- Serialize characters
- Compute FCS
- Generate flags
- Insert a 0 after each five 1's between flags

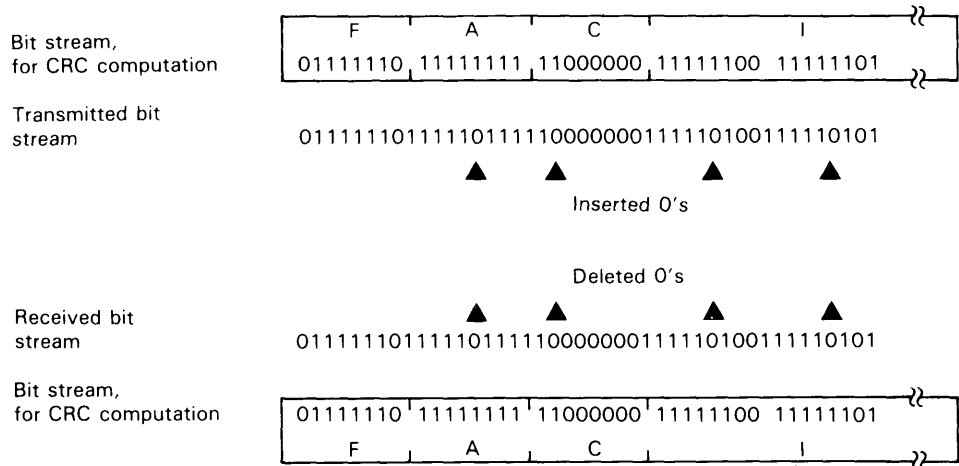

Figure 15. Zero Insertion and Deletion

Time Outs

The primary link station is responsible for the orderly, continuous operation of a data link, and it must check for responses to its commands. Two time outs are operated by a primary link station for these purposes: (1) idle detect and (2) nonproductive receive.

Idle Detect

When the primary station transmits a frame with the P bit *on* in the C field, the station expects a response to be initiated within a certain period of time. In two-way alternate operation, the link connection is normally in the idle state when no transmission is taking place. If the idle state (or nonresponse condition) continues past the time when a response should have been initiated (for example, if the secondary station does not respond to a frame), the primary station will detect the protracted idle condition and should initiate recovery action.

The interval that should be allowed before recovery action includes:

1. Propagation time to the secondary station
2. Clear-to-send time at the secondary station DCE
3. Appropriate time for secondary station processing
4. Propagation time from the secondary station.

Factors (1), (2), and (4) vary as follows:

Link Connection (<i>see Figure 16</i>)	Secondary Station DCE Clear-to-Send Delay	Approximate Two-Way Propagation Time (<i>see Figure 16</i>)
Switched (through local exchange only) or very short (distance) nonswitched	0 ms to 25 ms	2 ms per 15 miles (23 km.) (X)
Long (distance) duplex (nonswitched)	0 ms to 25 ms	2 ms per 150 miles (230 km.) + 24 ms (Y)
Long (distance) half-duplex (switched or nonswitched)	75 ms to 250 ms	2 ms per 150 miles (241 km) (Y)
Satellite duplex (switched or nonswitched)	0 ms to 250 ms	600 to 700 ms per hop ¹ plus propagation time for connecting terrestrial links (Z)

With each type of link connection configuration, the minimum time out includes an allowance for processing time at the secondary station. The sum of other times may be as great as 850-900 milliseconds (for a satellite link). If a response is received or is being received before the time out expires, the time out is reset.

¹ A satellite hop is one uplink and one downlink.

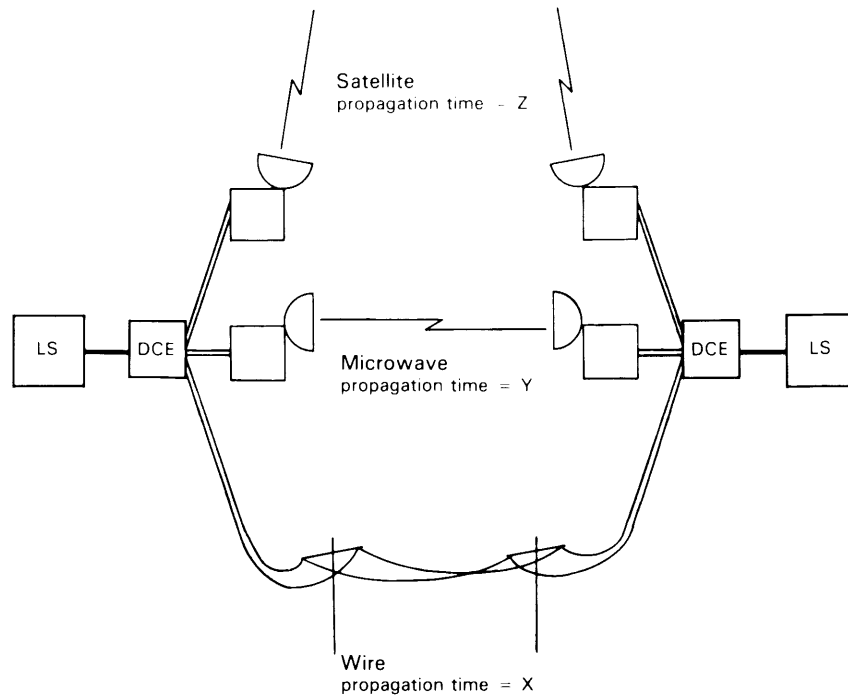

Figure 16. Examples of Telecommunication Facilities

Nonproductive Receive

When bits are being received that do not result in frames, a *nonproductive receive* condition exists. This condition could be caused by secondary station malfunctions that cause continuous transmission. The primary station must provide a time-out period when a nonproductive receive condition occurs. The usual time out period ranges from 3 to 30 seconds. If the nonproductive receive condition continues after the time out, the problem is normally not recoverable at the data link control level and must be handled by some method above the data link control level.

Abort Conditions

The act of prematurely terminating the transmission of a frame is called *aborting* the transmission.

The transmitting station aborts a transmission by sending a minimum of seven consecutive binary 1's with no zero insertion (see Figure 17). This sequence is called an *abort pattern*. (Unintentional aborting is prevented by zero insertion.) The abort pattern terminates the frame without an FCS field or an ending flag.

Following transmission of the abort pattern, the link connection may be permitted to go to the idle state or it may remain in the active state.

Abort and Idle Patterns

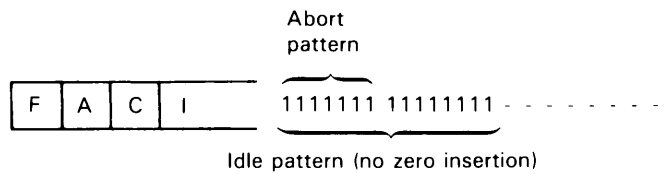

Abort Pattern and Flag

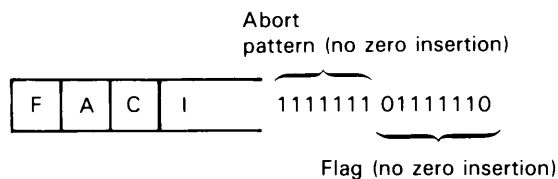

Figure 17. Transmitting Station Aborts Transmission

Either a primary or a secondary station may abort a transmission. An abort pattern of seven 1's may be followed by eight (minimum) additional 1's (a total of at least 15 contiguous 1's), which idles the data link as long as the 1's continue, or it may be followed by a frame. Seven to fourteen 1's constitute an abort pattern; fifteen or more 1's constitute an idle pattern.

Recovery from Errors and Special Conditions

SDLC detects various kinds of errors (such as CRC errors and frames out of order) and special conditions (such as a "busy" station). SDLC can provide recovery from some of these errors and conditions; the term *link-level recovery* is applied to these recovery actions. When unable to provide recovery from errors or special conditions, SDLC reports them to higher levels of SNA for resolution. The term *higher-level recovery* is applied to recovery actions outside SDLC.

Link-Level Recovery

At the link level, SDLC procedures detect discrepancies that may be recovered from by retransmitting the frame. For example:

- A busy station is temporarily unable to continue to receive. It reports this condition to the transmitting station.
- A received Nr count does not confirm the appropriate numbered information frames previously transmitted. Retransmission is initiated.
- A receiving station discards a frame because:
 - it contains a CRC error
 - it is out of numerical order

- the station cannot accept it because of a busy condition (I frames only)
- the ending flag is not displaced from the beginning flag by a multiple of 8 bits.
- it is less than 32 bits long.
- A response to a poll is not received; the poll is normally repeated.
- An attempt to bring a secondary station online does not succeed; the command is repeated.

Retransmissions may be counted to detect that the situation is not considered to be recoverable at the link level. The counting of retransmission attempts is not specified by SDLC procedures. Usually, they are counted within the transmitting DTE and, at some planned number n , correct link station action is reported as unrecoverable at the link level. Among those actions that should be retried are attempts to:

- Obtain acknowledgment of a command
- Resume communication with a busy station
- Achieve initial, online status of a secondary station.

Higher-Level Recovery

Link-level error detection applies to the address, control, information, and FCS fields of the frame. Some detected errors cannot be recovered from at the link level; for example:

- If a secondary station responds by rejecting a command with which the station is not compatible, only an acceptable alternative command can relieve its error condition. Intervention from a higher level is required to analyze and act upon the status report in the secondary station's response.²
- If the transmitting station has aborted transmission because of an internal malfunction or an expended retransmission count, intervention from a higher level is required to analyze and act upon the situation.
- If a secondary station response to the exchange of station identification (described under "SDLC on a Switched Link" on page 42) contains the wrong identification, intervention from a higher level is required to analyze and act upon the situation.

The type of intervention required depends upon the station's decision-making power at a level higher than the link level. At a terminal, for example, operator intervention may be needed.

² Rejecting a command is described under "FRMR (Frame Reject)" on page 40

Chapter 3. Further Concepts, Applications, and Examples

This chapter describes additional concepts, defines the SDLC commands and responses, and shows applications and examples of SDLC command and response flows for specific configurations.

Contents

Secondary-Station Mode Definitions	35
Initialization Mode	35
Normal Response Mode (NRM) and Normal Response Mode Extended (NRME)	35
Normal Disconnected Mode (NDM)	36
Command and Response Definitions	36
Unnumbered (U) Format	38
Supervisory (S) Format	41
Information (I) Format	42
SDLC on a Switched Link	42
SDLC in a Loop Configuration	42
Loop Operation	43
Primary Station Transmitting	43
Secondary Station Transmitting	44
Loop Commands	46
UP (Unnumbered Poll)	46
CFGR (Configure)	47
Loop Responses	49
BCN (Beacon)	49
CFGR (Configure)	49
Examples of SDLC Exchanges	51
Two-way Alternate Exchanges on Nonswitched Point-to-Point Links	52
Two-way Simultaneous Exchanges on Nonswitched Point-to-Point Links	54
Two-way Simultaneous Exchanges on Nonswitched Multipoint Links	56
Two-way Alternate Exchanges on Switched Point-to-Point Links	57
Two-Way Alternate Exchanges on SDLC Loops	58

Secondary-Station Mode Definitions

A secondary link station may be in one of three modes: *initialization mode*, *normal response mode*, or *normal disconnected mode*. The meanings of these modes are as follows.

Initialization Mode

Initialization mode is the mode for initializing or reinitializing a link station with the appropriate link protocols.

Normal Response Mode (NRM) and Normal Response Mode Extended (NRME)

A secondary station in either normal response mode (NRM) or normal response mode extended (NRME) does not initiate unsolicited transmissions. It transmits only in response to a poll, which is a frame received from the primary station, with the P bit *on* in the C field.

The secondary station may respond with one or more frames. The F bit is *on* in the last (or only) frame of the response. A primary station will not poll any other secondary station until (1) it receives the F bit response to an outstanding P bit or (2) a time out has completed.

Normal Response Mode: A secondary link station assumes normal response mode when it receives a SNRM (Set Normal Response Mode) command from the primary link station. The SNRM command causes modulo-8 operation of the link. In modulo-8 operation, each S frame and each I frame contains a 1-byte control field that includes 3 bits for the *Nr* count (and, for I frames only, 3 bits for the *Ns* count). The use of 1-byte control fields allows up to seven SDLC frames to be outstanding (that is, unacknowledged) on a link.

When in normal response mode, the secondary (1) expects every control field it receives in a command to be 1 byte long, and (2) sends only 1-byte control fields in its responses.

Normal Response Mode Extended (NRME): A secondary link station assumes normal response mode extended when it receives a SNRME (Set Normal Response Mode Extended) command from the primary link station. The SNRME command causes modulo-128 operation of the link. In modulo-128 operation, each S frame and each I frame contains a 2-byte control field that includes 7 bits for the *Nr* count, (and, for I frames only, 7 bits for the *Ns* count). The use of 2-byte control fields allows up to 127 SDLC frames to be outstanding (that is, unacknowledged) on a link.

When in normal response mode extended, the secondary (1) expects every control field it receives in a supervisory (S) or information (I) command to be 2 bytes long, and (2) sends only 2-byte control fields in its supervisory and information responses. Unnumbered (U) commands and responses contain 1-byte control fields.

Normal Disconnected Mode (NDM)

A secondary station that receives and accepts a DISC (Disconnect) command assumes normal disconnected mode; it also assumes this mode:

- When power is turned on, or when the station is enabled for data link operation
- Following a transient disabling condition (such as a power failure)
- When a switched connection is made.

In NDM, a secondary station will respond only as the result of receiving a command with the P bit *on* and may accept only a TEST, XID, CFGR, SNRM, SNRME, or SIM command from the primary station. One of these commands that is not accepted, or any other command in which the P bit is *on*, causes a disconnected secondary station to respond with a disconnected mode status or an initialization request.

Command and Response Definitions

This section describes the commands and responses contained in the C field of an SDLC frame. When received by a secondary station, a frame is a command; when received by a primary station, a frame is a response.

Commands and responses in the unnumbered (U) format have a 1-byte control field for both modulo-8 and modulo-128 operation of the link over which they pass. Commands and responses in the supervisory (S) and numbered information (I) formats have a 1-byte control field for modulo-8 operation of the link and a 2-byte control field for modulo-128 operation of the link.

Figure 18 summarizes all SDLC commands and responses.

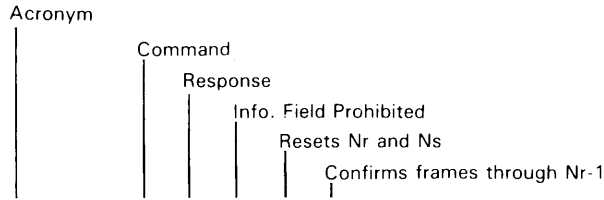

Binary format*

Defining Characteristics

Unnumbered (U) Format (Modulo 8 and 128)

Command	Response	Info. Field Prohibited	Resets Nr and Ns	Confirms frames through Nr-1	Defining Characteristics
000P 0011	UI	X			Unnumbered command that carries information.
000F 0011	UI		X		Unnumbered response that carries information.
000F 0111	RIM		X	X	Initialization needed; expect SIM.
000P 0111	SIM	X		X	Set initialization mode; the using system prescribes the procedures.
000F 1111	DM		X	X	This station is in disconnected mode.
001P 0011	UP	X		X	Response is optional if P bit is not on.
010P 0011	DISC	X		X	Do not transmit or receive information.
010F 0011	RD		X	X	This station wants to disconnect.
011F 0011	UA		X	X	Acknowledgment for unnumbered commands (SNRM, SNRME, DISC, or SIM).
100P 0011	SNRM	X		X	Set normal response mode; transmit on request by secondary only.
100F 0111	FRMR		X		Invalid frame received; must receive SNRM, SNRME, DISC, or SIM.
101P 1111	XID	X			Information field contains identification.
101F 1111	XID		X		Information field contains identification.
110P 0111	CFGR	X			Information field contains function descriptor.
110F 0111	CFGR		X		Information field contains function descriptor.
110P 1111	SNRME	X		X	Set normal response mode extended; transmit on request by secondary only.
111P 0011	TEST	X			Information field contains test pattern.
111F 0011	TEST		X		Information field contains test pattern.
111F 1111	BCN		X	X	Signals loss of input.

Supervisory (S) Format (Modulo 8)

Command	Response	Info. Field Prohibited	Resets Nr and Ns	Confirms frames through Nr-1	Defining Characteristics
rrrP 0001	RR	X		X	Ready to receive.
rrrF 0001	RR		X	X	Ready to receive.
rrrP 0101	RNR	X		X	Not ready to receive.
rrrF 0101	RNR		X	X	Not ready to receive.
rrrP 1001	REJ	X		X	Transmit or retransmit starting with frame Nr.
rrrF 1001	REJ		X	X	Transmit or retransmit starting with frame Nr.

Supervisory (S) Format (Modulo 128)

Command	Response	Info. Field Prohibited	Resets Nr and Ns	Confirms frames through Nr-1	Defining Characteristics
rrrr rrrP 0000 0001	RR	X		X	Ready to receive.
rrrr rrrF 0000 0001	RR		X	X	Ready to receive.
rrrr rrrP 0000 0101	RNR	X		X	Not ready to receive.
rrrr rrrF 0000 0101	RNR		X	X	Not ready to receive.
rrrr rrrP 0000 1001	REJ	X		X	Transmit or retransmit starting with frame Nr.
rrrr rrrF 0000 1001	REJ		X	X	Transmit or retransmit starting with frame Nr.

* Rightmost bit shown is transmitted first; leftmost bit is transmitted last.

F - Final bit (1 or 0); P - Poll bit (1 or 0)

r - Nr (receive count—1 or 0); s - Ns (send count—1 or 0)

Figure 18 (Part 1 of 2). Summary of Command and Response C Fields

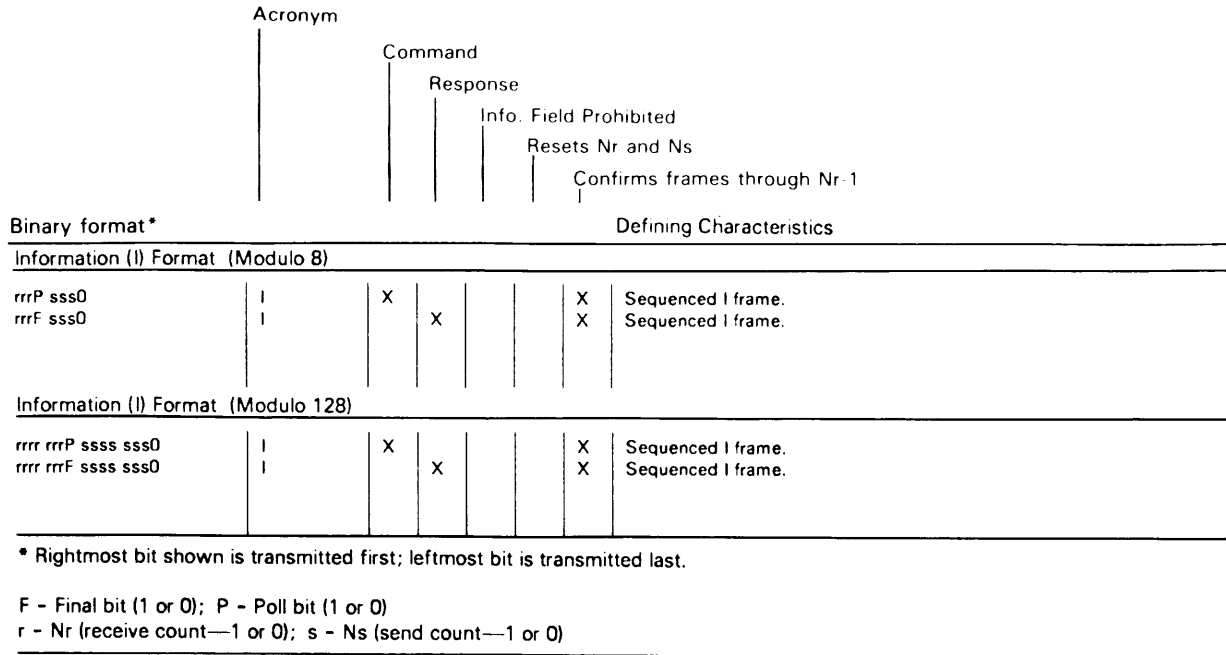

Figure 18 (Part 2 of 2). Summary of Command and Response C Fields

Unnumbered (U) Format

A C field in the unnumbered (U) format (see Figure 13) has the two low-order (first-sent) bits *on* (binary 11). Unnumbered frames are not sequence checked and do not use *Nr* or *Ns* counts. Excluding the P/F bit, the other five C field bits are available for encoding the commands and responses of U frames. These commands and responses are:

BCN	Beacon (<i>response</i>)
CFGR	Configure (<i>command or response</i>)
DISC	Disconnect (<i>command</i>)
DM	Disconnected Mode (<i>response</i>) ³
FRMR	Frame Reject (<i>response</i>) ⁴
RD	Request Disconnect (<i>response</i>) ⁵
RIM	Request Initialization Mode (<i>response</i>) ⁶
SIM	Set Initialization Mode (<i>mode-setting command</i>)
SNRM	Set Normal Response Mode (<i>mode-setting command</i>)
SNRME	Set Normal Response Mode Extended (<i>mode-setting command</i>)
TEST	Test (<i>command or response</i>)
UA	Unnumbered Acknowledgment (<i>response</i>) ⁷

³ Formerly ROL—Request Online.

⁴ Formerly CMDR—Command Reject.

⁵ Formerly RQD—Request Disconnect.

⁶ Formerly RQI—Request for Initialization.

⁷ Formerly NSA—Nonsequenced Acknowledgment.

UI	Unnumbered Information frame (<i>command or response</i>) ⁸
UP	Unnumbered Poll (<i>command</i>) ⁹
XID	Exchange Station Identification (<i>command or response</i>)

Note: For descriptions of UP, BCN, and CFGR, see “SDLC in a Loop Configuration” on page 42.

UI (Unnumbered Information): As a command or a response, a UI frame is the format for transmitting information without sequence numbers.

SNRM (Set Normal Response Mode) or SNRME (Set Normal Response Mode Extended): This command places the secondary station in normal response mode (NRM) or normal response mode extended (NRME) for information transfer. SNRM indicates that the transmissions on the link will be modulo 8 (that is, the *Nr* and *Ns* counts range in value from 0 to 7) and that each C field in a frame is 1 byte long. SNRME indicates that the transmissions on the link will be modulo 128 (that is, the *Nr* and *Ns* counts range in value from 0 to 127) and that each C field is 2 bytes long.

In either case, the maximum number of I frames that can be sent before an acknowledgment is required is the modulus minus 1—that is, 7 or 127. This means that consecutive *Nr* counts can be the same only if they confirm the same block of frames. See “Frame Numbering” on page 26 for additional information on *Nr* and *Ns* counts.

UA is the expected response. The primary and secondary station *Nr* and *Ns* counts are reset to 0. No unsolicited transmissions are allowed from a secondary station that is in NRM or NRME. The secondary station remains in NRM or NRME until it receives a DISC or SIM command.

DISC (Disconnect): This command terminates other modes and places the receiving (secondary) station in disconnected mode. The expected response is UA. (A link station on a switched link then disconnects, which is similar to hanging up a telephone.) A secondary station that is in disconnected mode cannot receive or send supervisory or information frames.

RD (Request Disconnect): This request is sent by a secondary station desiring to be disconnected (by a DISC command).

UA (Unnumbered Acknowledgment): This is the affirmative response to an SNRM, SNRME, DISC, or SIM command.

RIM (Request Initialization Mode): An RIM frame is transmitted by a secondary station to notify the primary station of the need for an SIM command.

SIM (Set Initialization Mode): This command initiates system-specified procedures that initialize link-level functions. UA is the expected response. The primary and secondary station *Nr* and *Ns* counts are reset to 0.

⁸ Formerly NSI—Nonsequenced Information frame.

⁹ Formerly NSP—Nonsequenced Poll.

DM (Disconnected Mode): A secondary station sends this response to indicate that it is in disconnected mode.

ID-frmresp.FRMR (Frame Reject): A secondary station that is in NRM or NRME sends this response only when it receives an invalid frame. A received frame may be invalid for any of several reasons:

- The function specified by its C field is not implemented at the secondary station. This category includes unassigned commands.
- The information field is too long to fit into the receiving station buffers. This use of FRMR is optional.
- The C field in the received frame does not allow an information field to be included with the frame, but an information field is present.
- The *Nr* count that was received from the primary station is invalid.

The secondary station cannot release itself from the FRMR condition, nor does it act upon the frame that caused the condition. It sends FRMR in response to any further commands it receives other than an acceptable mode-setting command (SNRM, SNRME, DISC, or SIM), which resets the frame-reject condition.

The secondary station sends an information field containing status as part of the FRMR response frame (see Figure 19).

TEST (Test): As a command, a TEST frame may be sent to a secondary station in any mode to solicit a TEST response. If an information field is included with the command, it is returned in the response. If the secondary station has insufficient buffering available for the information field, a TEST response with no information field is returned.

XID (Exchange Station Identification): As a command, XID solicits the identification of the receiving (secondary) station. An information field may be included in the frame to convey identification of the transmitting (primary) station. An XID response is required from the secondary station. An information field in the response may be used for identification of the responding secondary station.

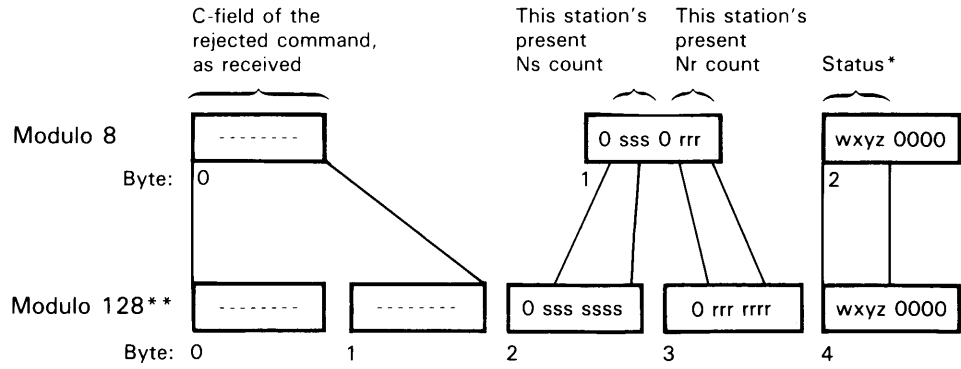

* Status: w - Invalid or nonimplemented command
 x - Prohibited information field received
 y - Buffer overrun (information field is too long)
 z - Received Nr count is invalid

**When the FRMR response rejects an unnumbered (U) format command the rejected C field is placed in byte 0 and byte 1 is set to all 0's.

Figure 19. Information Field of the FRMR Response

Supervisory (S) Format

Supervisory (S) frames may be used to acknowledge receipt of I frames and to control information interchange. No information field is permitted in the S frame itself. The 2 low-order bits of the C field in this format (the first 2 bits sent) are 1 and 0 (binary 10) (see Figure 13). Excluding the 4 bits for P/F and the Nr count, 2 bits remain for encoding the commands and responses of S frames. These commands and responses are:

RR Receive Ready (*command or response*)
 RNR Receive Not Ready (*command or response*)
 REJ Reject (*command or response*)

RR (Receive Ready): Sent by either a primary or a secondary station, RR confirms numbered frames through Nr-1 and indicates that the originating station is ready to receive additional I frames.

RNR (Receive Not Ready): Sent by either a primary or a secondary station, RNR indicates a temporarily busy condition caused by unavailability of buffers or other internal constraints.

As a command or response, RNR confirms numbered information frames through Nr-1 and indicates that frame Nr is expected next.

A secondary station reports the clearing of a Receive Not Ready condition by transmitting an I frame with the F bit *on* or an RR or REJ frame with the F bit *on* or *off*.

A primary station indicates that a Receive Not Ready condition has been cleared by transmitting an I frame with the P bit *on* or an RR or REJ frame with the P bit *on* or *off*.

REJ (Reject): This command or response may be transmitted to request transmission or retransmission of numbered information (I) frames. REJ confirms frames through $Nr-1$ and requests the retransmission of numbered information frames starting at the Nr count contained in the REJ frame. An REJ command or response may be interspersed in the sequence of transmitted frames. The Reject condition is cleared when the requested frame or a mode-setting command has been correctly received.

Information (I) Format

Information (I) frames are sequentially numbered by the transmitting station. The Ns count provides for numbering the frame being sent and the Nr count provides acknowledgment for the I frames received. When information is being sent in both directions simultaneously, each station reports its current Ns or Nr counts, or both, in each I or S frame exchanged.

The expected acknowledgment is an S or I frame whose Nr count confirms correctly received frames. (S frames may be interspersed with I frames, as needed.)

SDLC on a Switched Link

One of the participating stations on a switched link must act as a primary station. The other station must assume the role of the secondary station. The primary station manages the link; it initiates and controls the information exchange.

The SDLC procedures allow the stations to identify themselves to each other using an XID command/response exchange. The use of XID is *not* restricted to a switched link.

The SDLC procedures for a switched link are essentially the same as for a nonswitched point-to-point link. An "inactivity" time out (on conditions similar to nonproductive receive¹⁰) is required to alert switched stations of link inactivity. If the time out expires at either station, that station may attempt to alert the other. After a user-specified number of unsuccessful attempts, the station with the expired time out disconnects the switched link connection by "going on hook." This is equivalent to "hanging up" a telephone.

SDLC in a Loop Configuration

For some applications, a loop configuration may be preferable to a multipoint configuration for the interconnection of multiple secondary stations to the primary station.

A loop consists of a simplex (one-way only) link connection. The link connection originates at the transmit port of the primary station, connects one

¹⁰ Described under "Time Outs" on page 28

or more secondary stations in a serial fashion, and then terminates back at the receive port of the primary station. Figure 20 shows a loop having five secondary stations.

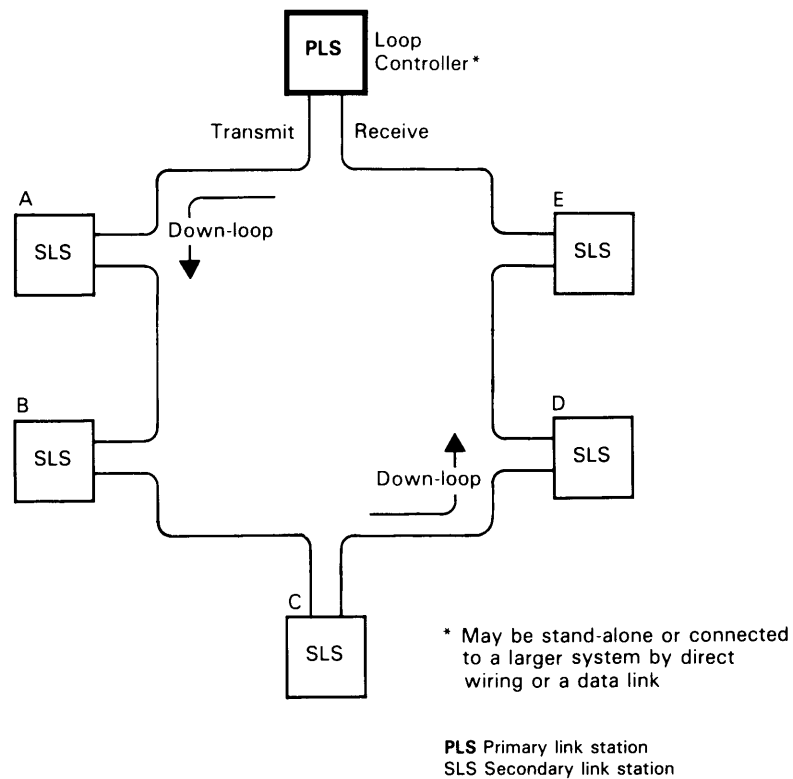

Figure 20. Loop Configuration

Loop Operation

The link stations on a loop use two-way alternate operation, even though transmissions flow between the DCEs on the loop in one direction only. Only one station, the primary or a secondary, transmits at any moment. The secondary stations transmit sequentially in the order in which they are attached to the link connection.

Primary Station Transmitting

The primary station sends command frames that are addressed to any or all of the secondary stations on the loop. Each frame it sends carries the individual, group, or broadcast address of the station or stations to which the frame is directed.

Every secondary station on the loop decodes the address field of each frame the primary station sends and serves as a repeater for all primary transmissions to the down-loop stations (see Figure 21). Upon detecting a frame containing its station address, a group address for a group to which it belongs, or the broadcast address, the secondary station accepts the frame from the loop for processing. The secondary also passes the frame to down-loop stations.

When the primary has finished sending frames, it follows the last flag with a minimum of eight consecutive 0's (a flag followed by eight 0's is a turnaround sequence). It then transmits continuous 1's, which create a go-ahead sequence (01111111). In this way, the primary totally controls all loop communication. The primary, while continuing to transmit 1's, goes into receive mode.

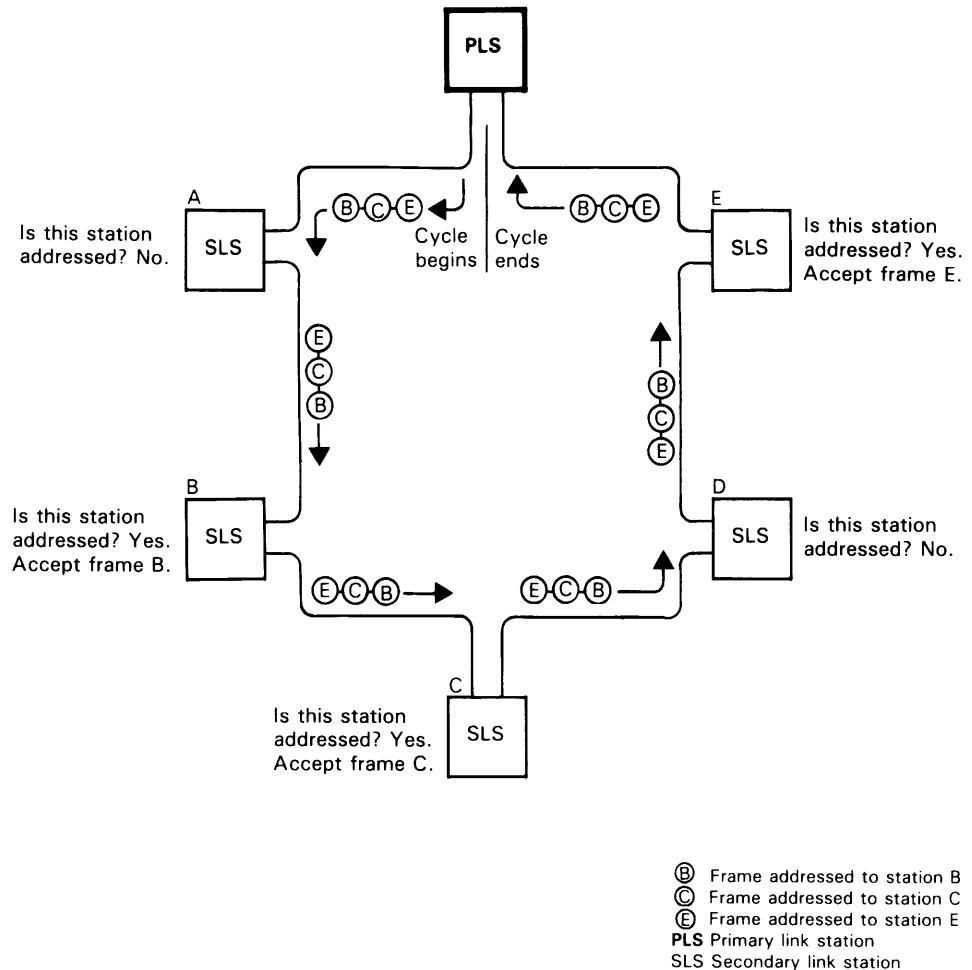

Figure 21. SDLC Loop Exchanges: Primary Station Transmitting

Secondary Station Transmitting

In this description, the primary station has completed transmission, has placed itself in receive mode, and is transmitting continuous 1's—the go-ahead sequence (see Figure 22).

Before transmitting on the loop, a secondary station must have received a frame addressed to it with the P bit *on*, or received a UP-command frame with the P bit *off*. In the case of a UP frame with the P bit *off*, a secondary station transmission is optional if a response is not required for acknowledgment or status purposes.

The first down-loop secondary detects the go-ahead sequence. If it has a response to send, the secondary changes the seventh 1-bit to a 0-bit, thereby

creating a flag. It follows the flag with one or more response frames that contain its individual address. After sending its last frame, the secondary again becomes a repeater, forwarding the continuous 1-bits it receives from the primary station.

The next down-loop secondary operates similarly when it detects the go-ahead sequence that results from the continuous 1-bits.

This procedure continues until the last down-loop secondary to transmit completes its transmission. The cycle completes when the primary receives its own turnaround sequence and a series of response frames from all the secondary stations that responded, if any.

If a secondary does not convert the go-ahead sequence received after the turnaround sequence into a flag, it forfeits that opportunity to transmit.

To abort a transmission, a secondary needs only to stop sending the transmission and to pass on the incoming 1-bits. It need not generate its own abort sequence.

If, when transmitting, a secondary receives eight contiguous 0-bits, it must terminate its transmission. This is called the *shut-off sequence* and is originated by the primary station.

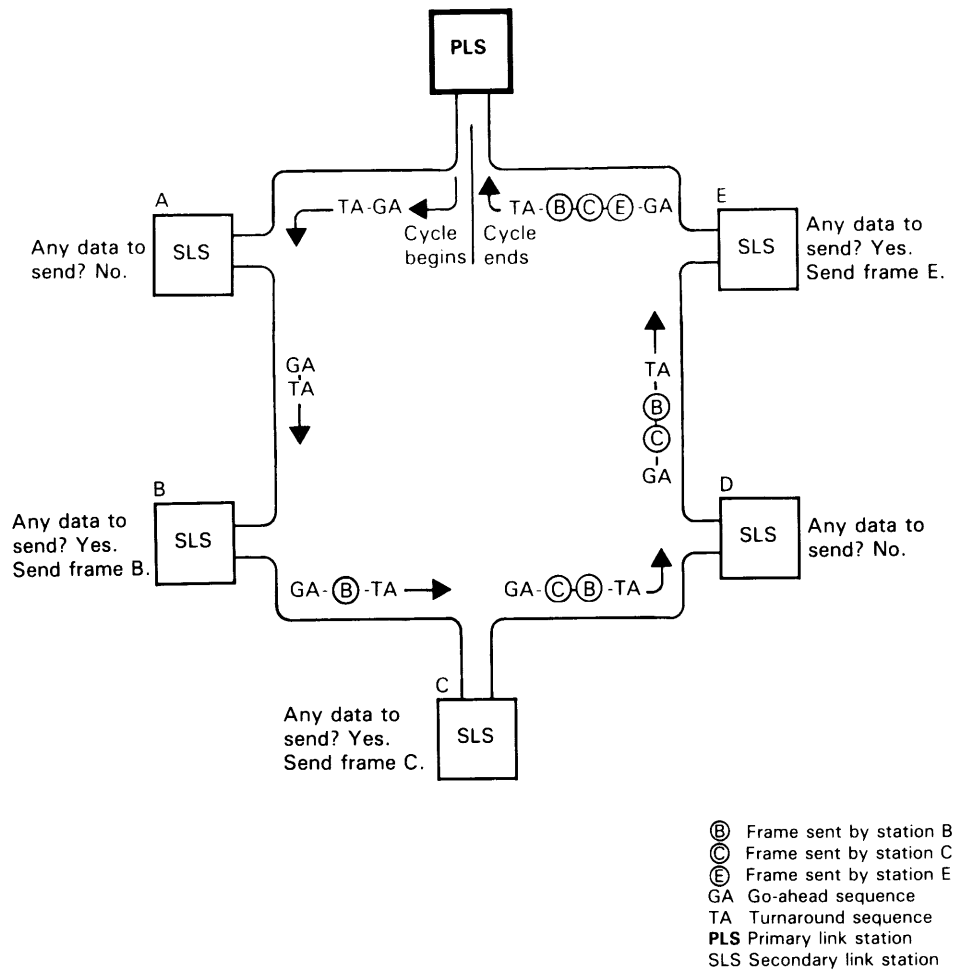

Figure 22. SDLC Loop Exchanges: Secondary Stations Transmitting

Loop Commands

UP (Unnumbered Poll)

The Unnumbered Poll command with the P bit set to 0 provides a function that is particularly useful in loop configurations. While a poll of all addressed (station, group, or broadcast) secondary stations is being performed, a response transmission is optional and depends on the actual need for each secondary station to transmit.

UP With P Bit Set To 0: The primary station sends an optional response poll (UP with P bit set to 0) to poll one station, a group of stations, or all the stations on the loop. A response is not necessarily required. Individual secondary stations will respond if one of the following conditions exists:

- The secondary has received one or more numbered I frames since the last time it responded. The secondary must send a confirming *Nr* to the primary signifying its acceptance of the frames.

- The secondary has received an unnumbered command that requires a response since the last time it responded.
- An exception condition has occurred since a previous response opportunity and an appropriate response frame is pending transmission or retransmission.

Exception conditions are problems that occur because of transmission errors, station malfunctions, or operational constraints. Examples include busy conditions; frame numbering errors; and frames rejected because of invalid control fields, invalid *Nr* counts, or overlong information fields.

- The secondary has changed from the Receive Ready to the Receive Not Ready condition since the last time it responded.
- The secondary has changed from the Receive Not Ready to the Receive Ready condition since the last time it responded.
- The primary has not acknowledged one or more I frames transmitted by the secondary and the secondary retransmits the unacknowledged I frames.
- The secondary is in disconnected mode and sends a DM response to request a mode-setting command (SNRM) to become operational.

If none of the preceding conditions exists, the response is optional and may be sent if information frames are pending initial transmission.

UP with P Bit Set to 1: A mandatory response poll (UP with P bit set to 1) is addressed to an individual station, a group of stations, or all the secondary stations on a loop. It serves to perform an unnumbered poll of the addressed secondary stations. The stations that are addressed by a mandatory response poll *must* respond.

A polled station will respond either with frames it has waiting to transmit or retransmit, or, if no such frames exist, with another appropriate response (RR, RNR, or DM).

CFGR (Configure)

A primary station uses the CFGR command to cause various diagnostic operations to be performed by a secondary station. Upon receiving a CFGR command, a secondary station transmits a CFGR response to acknowledge it.

The CFGR command contains a function descriptor subcommand in a single-byte information field. These subcommands are listed below. Following the name of each subcommand is its bit configuration in the information field; an X in the low-order bit position means that the bit can be set to either 0 or 1. If it is set to 1, the specified function is to be started. If it is set to 0, the function is to be stopped.

- **Clear (00000000)**
Clear causes the secondary station to stop all functions that it previously started when it received the CFGR command.

- **Beacon Test** (0000001X)
Beacon Test causes the secondary station receiving it to suppress the transmission of the carrier, or to begin transmitting the carrier again after suppressing it. If X is a 1-bit, the secondary is to suppress transmission. If X is a 0-bit, the secondary is to resume transmission.

Note: If the carrier is ordered suppressed at a secondary station, the next down-loop secondary will transmit BCN responses indicating loss of the carrier.

- **Monitor Mode** (0000010X)
This subcommand causes the addressed secondary to place itself in a monitor mode, that is, a receive-only mode. Once a secondary is in the monitor mode, it cannot transmit until it receives a Monitor Mode Clear (00000100) or Clear (00000000) subcommand.
- **Wrap** (0000100X)
The Wrap subcommand causes the secondary station to wrap its transmission output directly into its receiving input. This effectively places the secondary station offline for the duration of the wrap test.
- **Self-Test** (0000101X)
The Self-Test subcommand causes the addressed secondary to begin a series of internal diagnostic tests. The secondary will not respond until the tests are complete. If the poll bit in the CFGR command was set to 1, the secondary will respond following completion of the internal tests at its earliest opportunity to respond. However, if the poll bit in the CFGR command was set to 0, the secondary will, following completion of the test, respond to the next poll-type frame it receives. The secondary ignores all other transmissions it receives while it is testing after receiving a Self-Test subcommand.

The secondary indicates the results of the tests by setting the low-order bit (X) in the information field of its response to either 1 or 0. A 1 indicates that the tests were unsuccessful. A 0 indicates that they were successful. Regardless of the results of the tests, the test function is ended.

- **Modified Link Test** (0000110X)
This subcommand (if incorporated) provides an alternative form of link test to that previously described for the TEST command and response (see "TEST" under "Unnumbered (U) Format" on page 38).

If the modified-link-test function is started (X bit is set to 1), the secondary station will respond to a TEST command with a TEST response that has an information field. This field contains the first byte of the TEST command information field, if any, repeated *n* times; the number *n* is implementation dependent. If the TEST command has no information field, the TEST response contains *n* bytes; the configuration of these bytes is implementation dependent.

If the modified-link-test function has not been set (X bit is set to 0), the secondary station will respond to a TEST command (with or without an information field) with a TEST response having a zero-length information field.

Loop Responses

BCN (Beacon)

Upon detecting the loss of communication at its input, a secondary station begins to transmit a BCN response. This allows the primary station to locate the problem in the loop and to take appropriate action. In the BCN response, the F bit can be either a 1 or a 0. As soon as the input resumes normal status (the problem that caused the secondary to send the BCN response is solved), the secondary stops transmitting the BCN response.

CFGR (Configure)

The CFGR response is transmitted by secondary stations only in response to a CFGR command. The structure of the CFGR responses is identical to that of the CFGR commands. If the low-order bit in the information field of the response is set to 1, the configure function specified by the function-descriptor subcommand in the information field has been started. If the low-order bit in the information field is set to 0, the configure function specified by the function-descriptor subcommand has been stopped. The configure function that the secondary station is responding to is the same one specified in the first 7 bits of the function-descriptor subcommand in the CFGR command.

Note: When performing *some* CFGR subcommands (for example, Self-Test), the secondary may not respond to CFGR commands until the function is completed.

Examples of SDLC Exchanges

Figure 24 through Figure 28, which conclude this chapter, show examples of SDLC exchanges of data and control information for:

- Two-way alternate exchanges on nonswitched point-to-point links
- Two-way simultaneous exchanges on nonswitched point-to-point links
- Two-way simultaneous exchanges on nonswitched multipoint links
- Two-way alternate exchanges on switched point-to-point links
- Two-way alternate exchanges on SDLC loops.

Figure 23 shows the symbolic format for the commands and responses that appear in these example.

In the examples, time progresses downward; trailing vertical lines indicate a duration of information-field transmission. The order of transmission of the A (address) and C (control) fields as shown is left to right, regardless of the direction of the arrow.

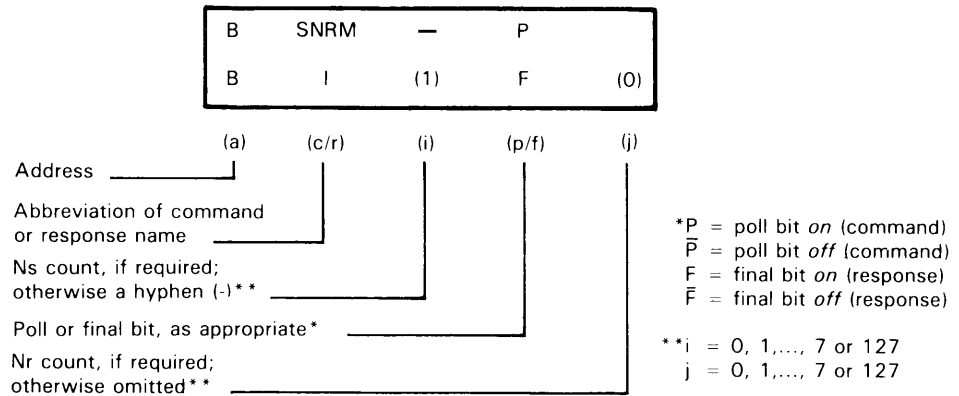

Figure 23. Format of Examples of SDLC Exchanges

Two-way Alternate Exchanges on Nonswitched Point-to-Point Links

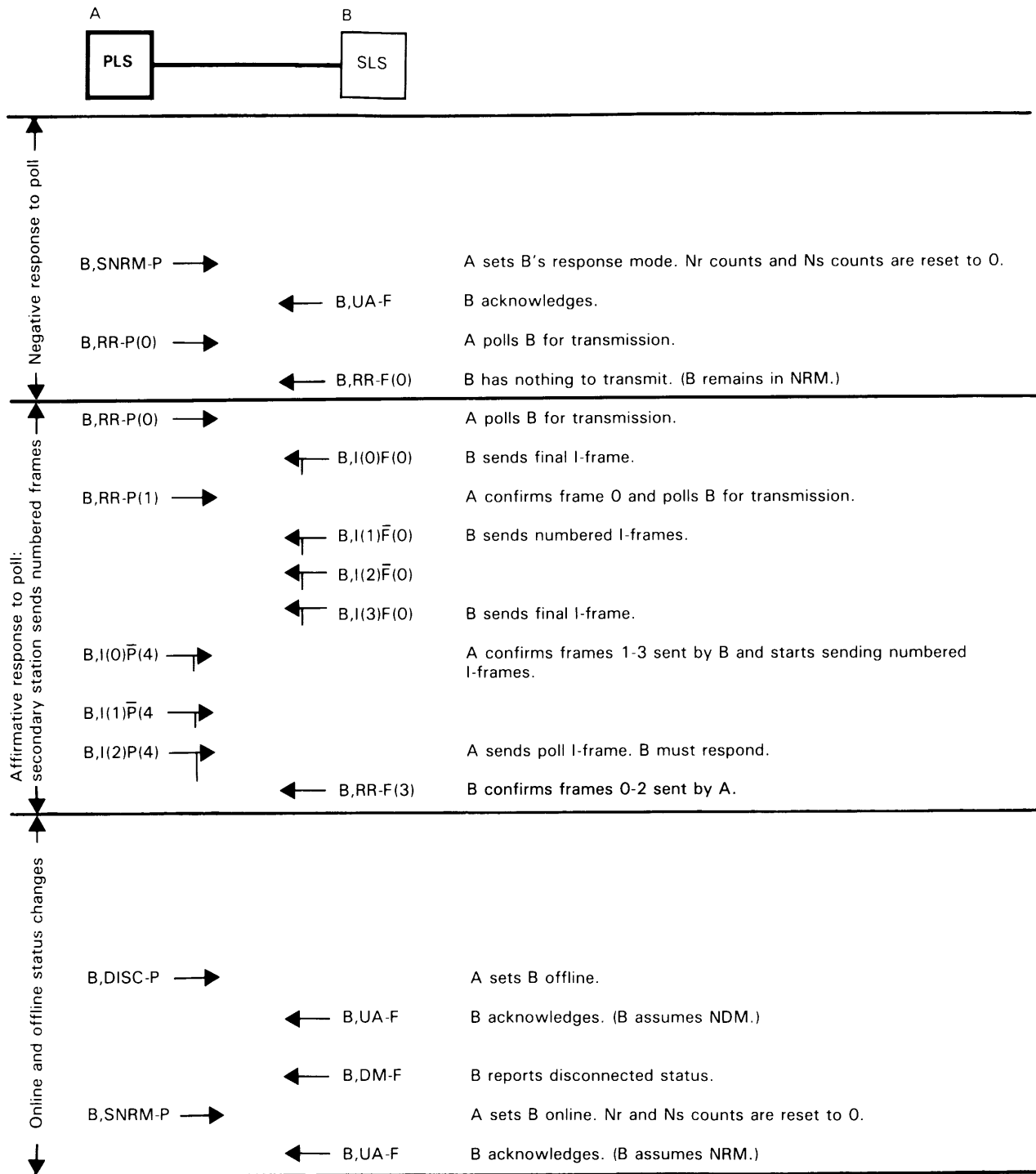

Figure 24 (Part 1 of 2). Two-way Alternate Exchanges on Nonswitched Point-to-Point Links

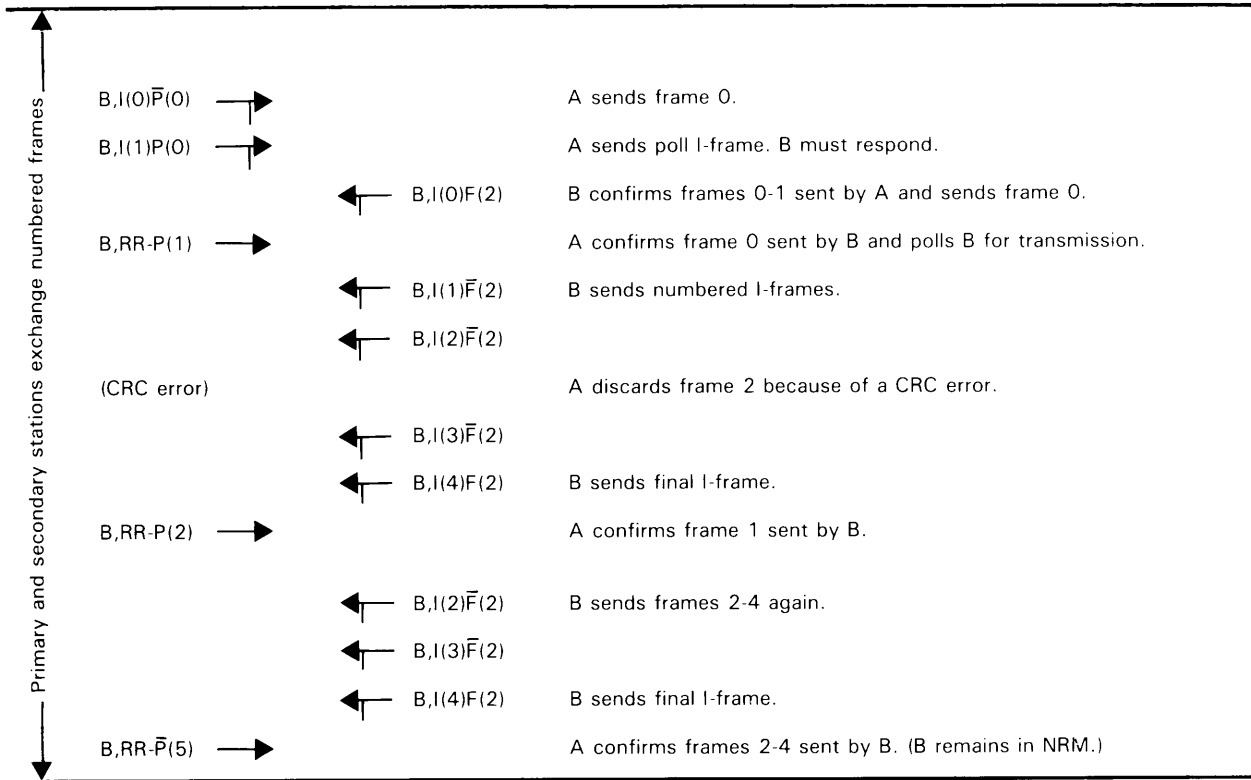

Figure 24 (Part 2 of 2). Two-way Alternate Exchanges on Nonswitched Point-to-Point Links

Two-way Simultaneous Exchanges on Nonswitched Point-to-Point Links

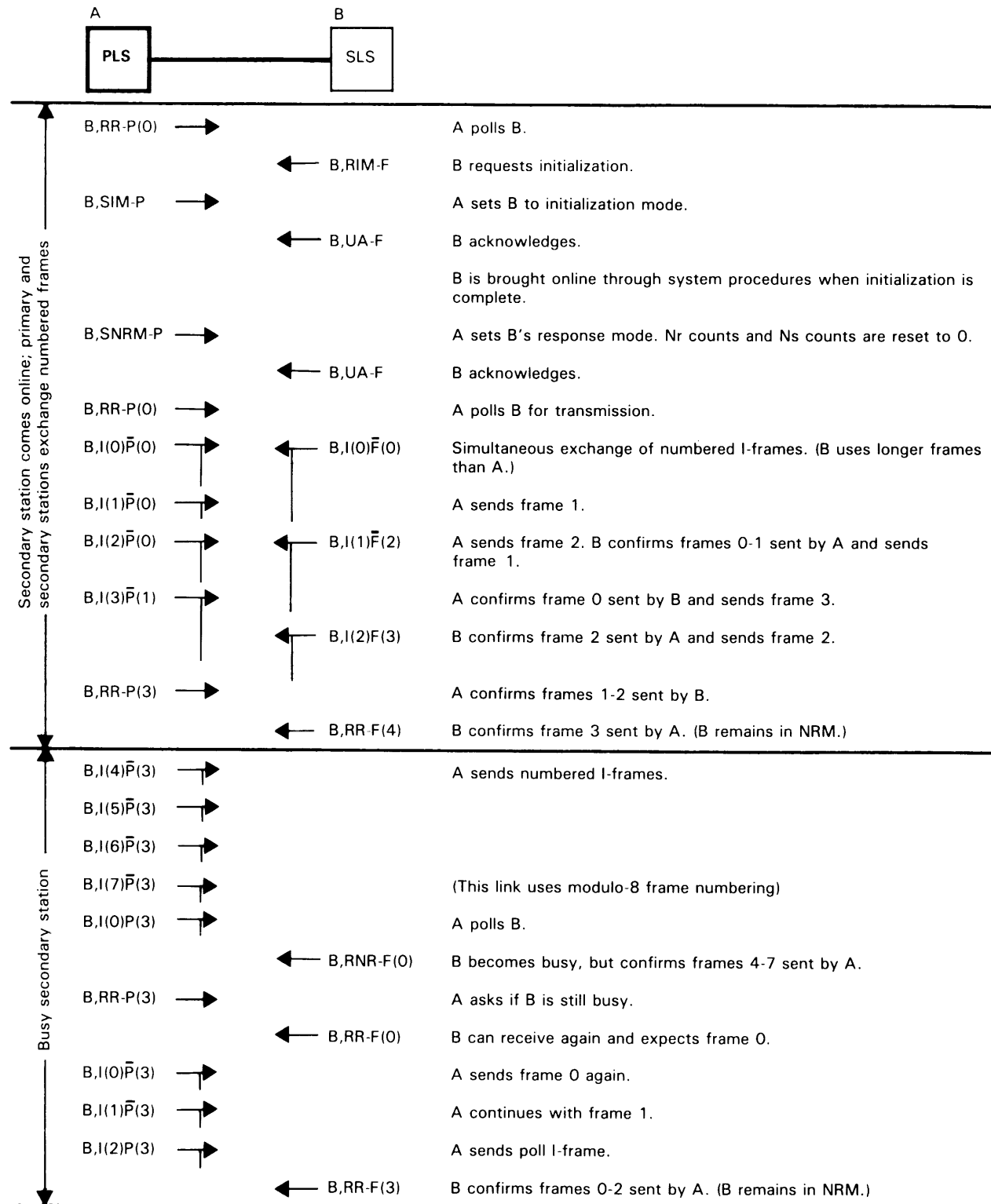

Figure 25 (Part 1 of 2). Two-way Simultaneous Exchanges on Nonswitched Point-to-Point Links

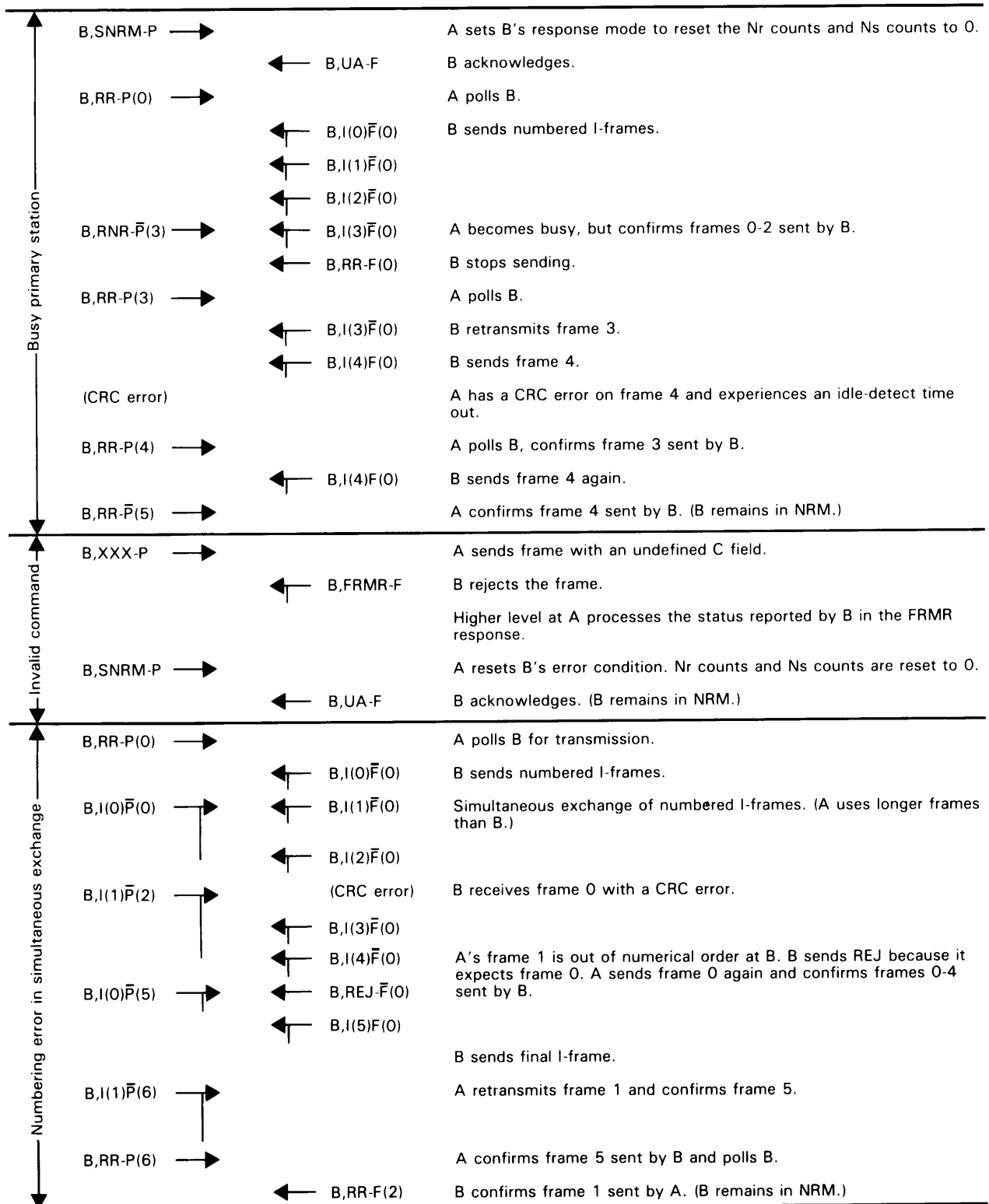

Figure 25 (Part 2 of 2). Two-way Simultaneous Exchanges on Nonswitched Point-to-Point Links

Two-way Simultaneous Exchanges on Nonswitched Multipoint Links

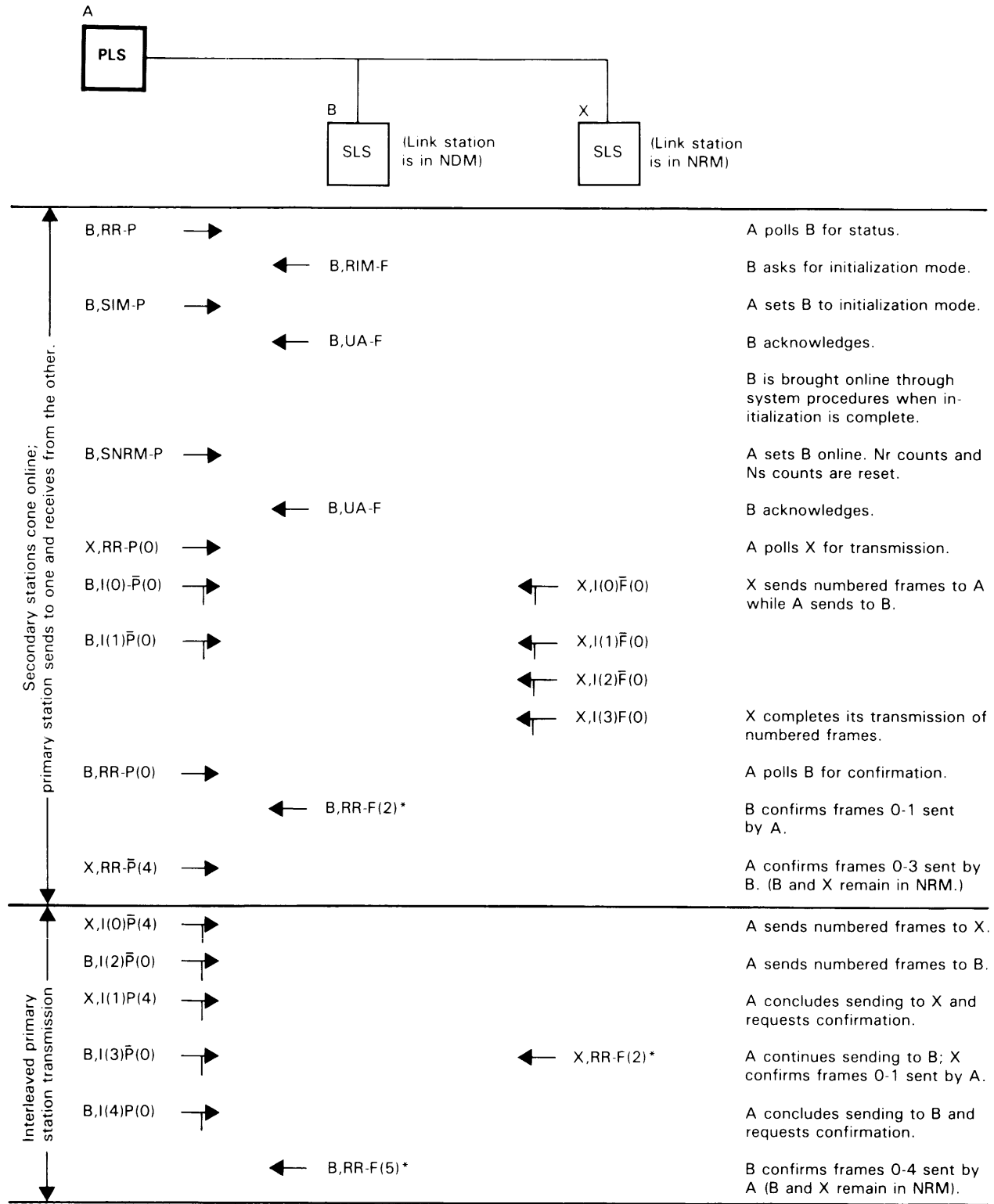

Figure 26. Two-way Simultaneous Exchanges on Nonswitched Multipoint Links

Two-way Alternate Exchanges on Switched Point-to-Point Links

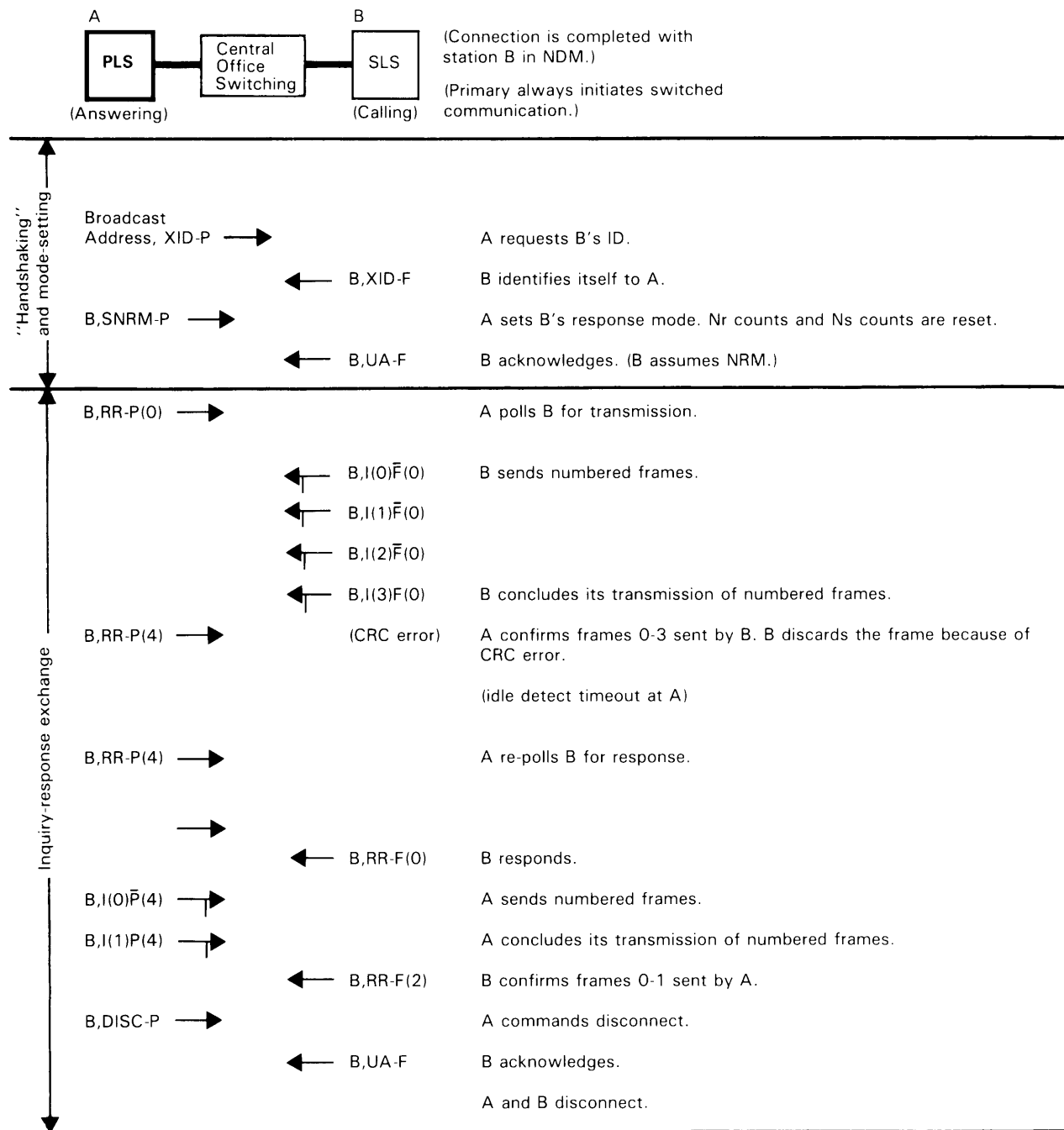
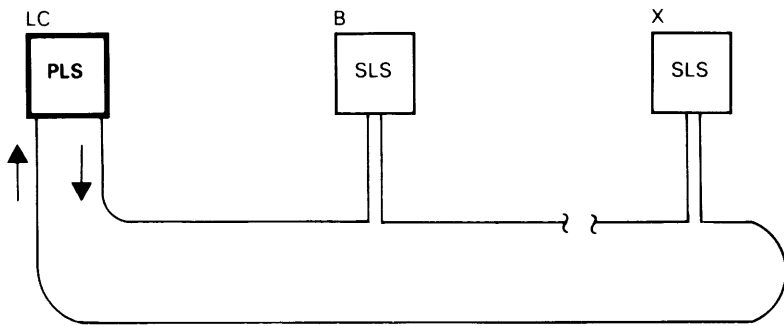

Figure 27. Two-way Alternate Exchanges on Switched Point-to-Point Links

Two-Way Alternate Exchanges on SDLC Loops



Secondary stations come on in NDM

ba = broadcast address (established by the using system)

flag = SDLC F (01111110)

GA = Go-ahead sequence

LC = Loop Controller

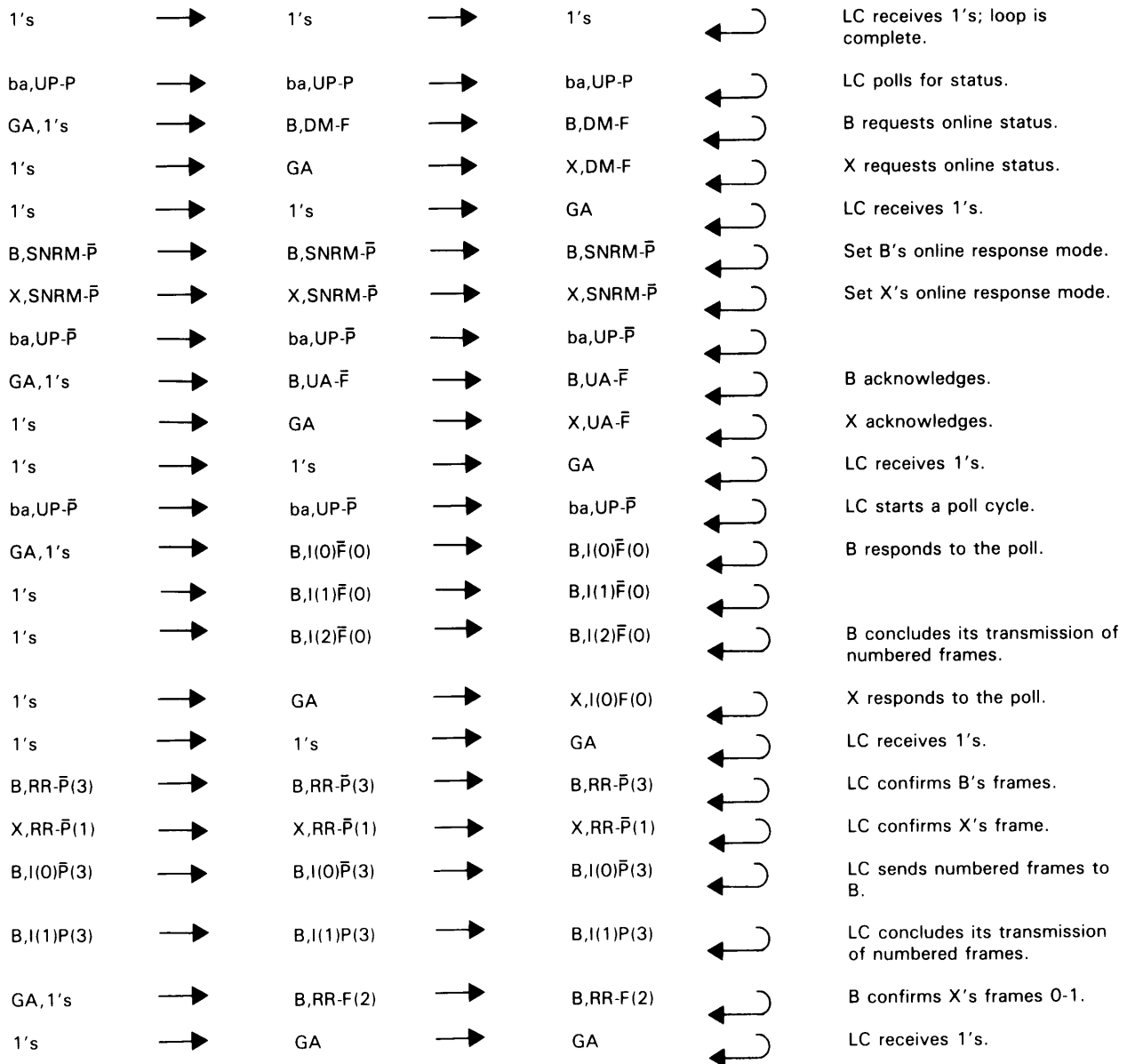

Figure 28 (Part 1 of 2). Two-Way Alternate Exchanges on SDLC Loops

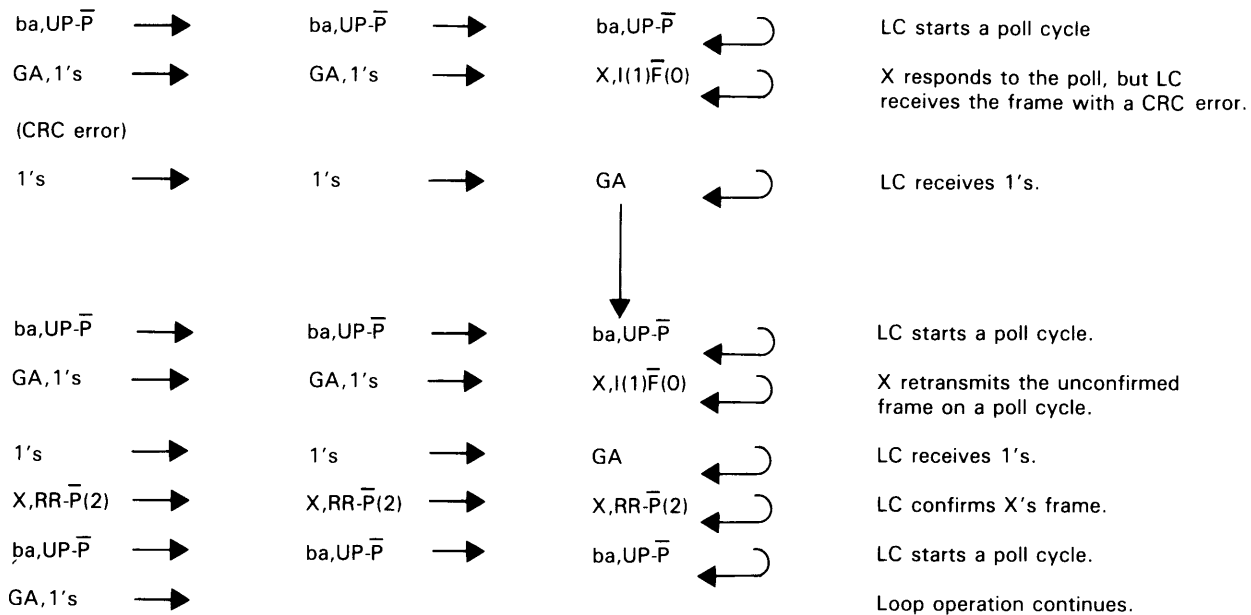

Figure 28 (Part 2 of 2). Two-Way Alternate Exchanges on SDLC Loops

Appendixes

Contents

Appendix A. SDLC Frame Summary	63
Appendix B. SDLC Computation of the FCS Field	65
Appendix C. IBM SDLC and Data Link Control Standards	69

Appendix A. SDLC Frame Summary

Supervisory (S) Format

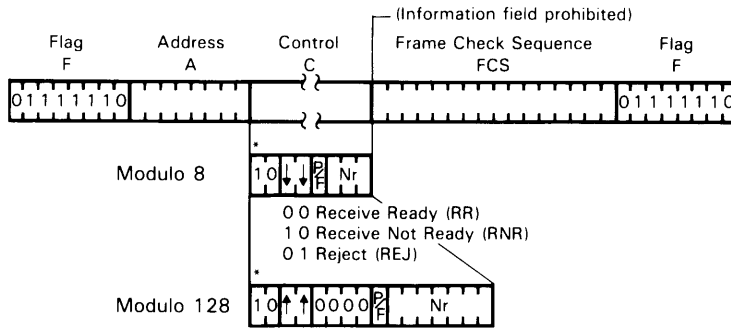

Information (I) Format

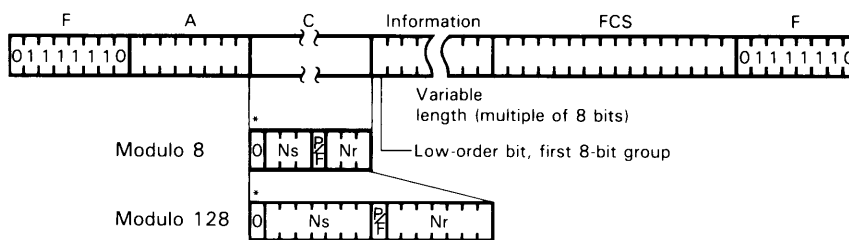

Unnumbered (U) Format**

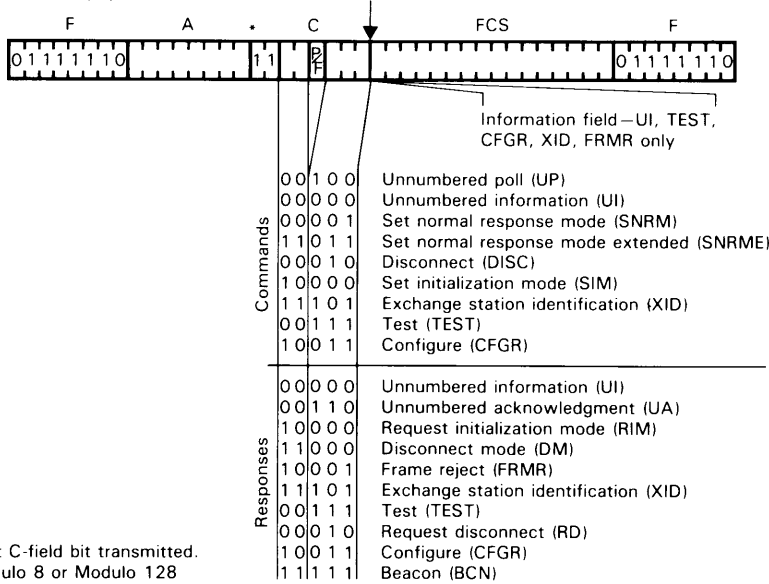

*First C-field bit transmitted.

**Modulo 8 or Modulo 128

Figure 29. SDLC Frames, As Transmitted

Appendix B. SDLC Computation of the FCS Field

This appendix shows how SDLC computes the value of the FCS (frame check sequence) field of transmission frames. For an overview of the FCS field, see (1) "Frame Check Sequence (FCS) Field" on page 26 and (2) Figure 15.

Note: This appendix is not intended as a text on the use and computation of the FCS field.

In the SDLC implementation of cyclic redundancy checking (CRC) for the FCS field, the CRC computation at the transmitter starts with the first bit following the opening flag (A field) and stops at the end of the data (information field or control field). (The FCS field is an inversion, or ones-complement, of the transmitter's remainder at that point.) The result of a transmission correctly received is a constant: 1111000010111000 (x_0 through x_{15} —see Figure 30).

In the SDLC application of CRC, a modified polynomial expression (modulo 2) of the transmission to be checked is divided by the generating polynomial, $X^{16} + X^{12} + X^5 + 1$. Integer quotient digits are ignored, and the transmitter sends the complement of the resulting remainder value as the FCS field (see Figure 31).

In addition to the division of the binary value of the data by the generating polynomial to generate a remainder for checking, the following manipulations occur:

1. The dividend is initially preset to all-1's (see Figure 30). This adds the binary value of the preset bits to that of the data bits.
2. The transmitter's remainder is inverted bit by bit (FCS field) as it is sent to the receiver. The high-order bit of the FCS field is transmitted first.
3. The receiver treats the FCS field as part of its dividend. Continued computation raises the value of the dividend polynomial by the factor X^{16} . Since the dividend/remainder at the receiver is equal to that at the transmitter at the beginning of the FCS field, the remainder at the receiver at the end of the FCS field is a constant that is characteristic of the divisor.

If a receiver computation does not yield the constant, 1111000010111000, it is assumed that the frame was received in error. Its entire content is suspect and is discarded; no action is taken. The transmitter is responsible for determining that the receiver has not accepted that frame.

		Transmitter Computation-- Dividend/Remainder (preset to 1's)*				Receiver Computation-- Dividend/Remainder (preset to 1's)*					
Input to Transmitter (Sent and computed)		X ₀	X ₅	X ₁₂	X ₁₅	Input to Receiver (Received and computed)		X ₀	X ₅	X ₁₂	X ₁₅
Preset		11111	11111111	1111		11111		11111	11111111	1111	
Hypothetical 19-bit Frame	0	11111	01111111	0111		0	11111	01111111	0111		
	1	01111	10111111	1011		1	01111	10111111	1011		
	1	00111	11011111	1101		1	00111	11011111	1101		
	1	00011	11101111	1110		1	00011	11101111	1110		
	1	10001	01111011	0111		1	10001	01111011	0111		
	0	11000	00111101	0011		0	11000	00111101	0011		
	0	11100	10011110	0001		0	11100	10011110	0001		
	1	01110	01001111	0000		1	01110	01001111	0000		
	1	10111	10100111	0000		1	10111	10100111	0000		
	0	01011	11010011	1000		0	01011	11010011	1000		
	0	00101	11101010	1100		0	00101	11101010	1100		
	1	10010	01111010	1110		1	10010	01111010	1110		
	1	11001	10111101	1111		1	11001	10111101	1111		
	0	11100	01011110	0111		0	11100	01011110	0111		
	0	11110	10101111	1011		0	11110	10101111	1011		
	0	11111	11010111	0101		0	11111	11010111	0101		
	1	01111	11101010	1010		1	01111	11101010	1010		
	1	10111	01111010	0101		1	10111	01111010	0101		
	1	01011	10111101	0010		1	01011	10111101	0010		
Invert and shift out FCS		00101	11011110	1001	→	1	10101	01011110	0001		
		00010	11101111	0100	→	0	11010	00101111	1000		
		00001	01111011	1010	→	1	11101	10011011	0100		
		00000	10111101	1101	→	1	11110	01001010	0010		
		00000	01011110	1110	→	0	01111	00100110	1001		
		00000	00101111	0111	→	1	00111	10010010	0100		
		00000	00010111	1011	→	0	00011	11001000	1010		
		00000	00001011	1101	→	0	00001	11100110	0101		
		00000	00000110	1110	→	0	10000	01111001	1010		
		00000	00000011	0111	→	1	11000	10111100	0101		
		00000	00000000	1011	→	0	11100	11011110	1010		
		00000	00000000	0101	→	0	01110	01101111	0101		
		00000	00000000	0010	→	0	10111	10111011	0010		
	00000	00000000	0001	→	1	11011	01011101	0001			
	00000	00000000	0000	→	0	11101	00101110	0000			
	00000	00000000	0000	→	1	11110	00010111	1000			

*Generator polynomial (divisor) = $X^{16} + X^{12} + X^5 + 1$, exemplified in shift register form:

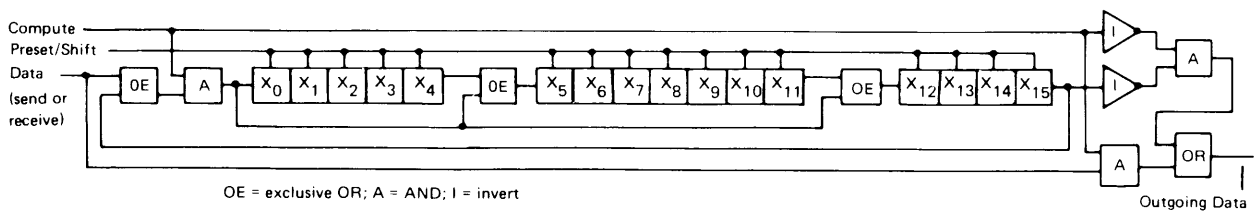

Figure 30. An Example of Cyclic Redundancy Checking

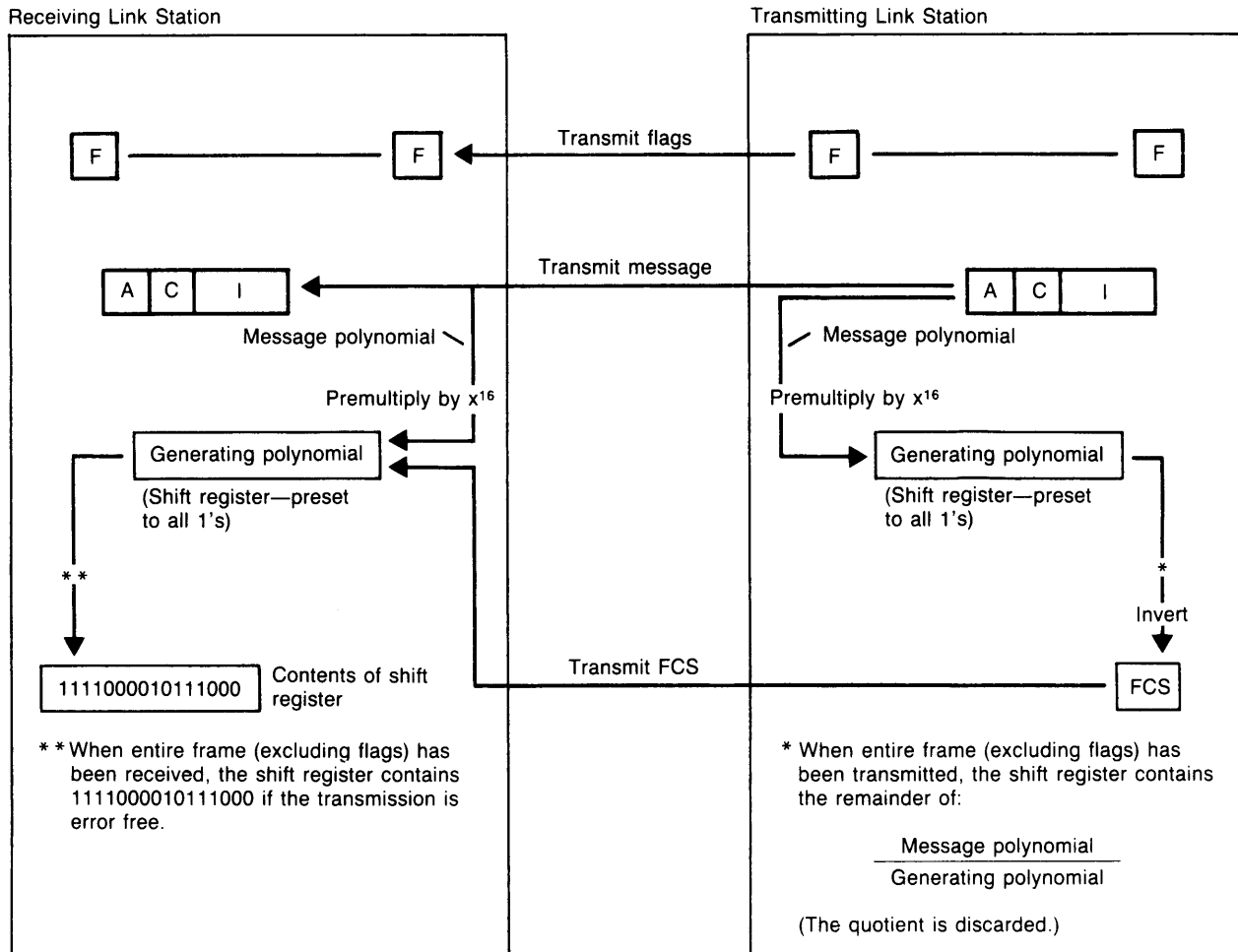

Figure 31. CRC Operation with SDLC

Appendix C. IBM SDLC and Data Link Control Standards

It is IBM's technical judgment that SDLC, as implemented in IBM telecommunication products, conforms with a defined operational subset of ISO HDLC: the Unbalanced Normal Class of Procedure. SDLC, as implemented in IBM telecommunication products, is more precise in certain aspects than the HDLC standards.

International standards are generally written to provide a wide freedom of choice for both function and configuration selection depending on application needs and objectives.

The ISO HDLC approved and proposed standards comprise several interrelated standards, which are designated as follows:

- **ISO International Standard (IS) 3309, Data Communications—High-Level Data Link Control Procedures—Frame Structure (1984)**

This standard specifies the format of the HDLC transmission unit (frame). It identifies the functional fields of the frame (address, control, information, and frame check sequence) and the location of each. In addition, it specifies:

- The unique 8-bit framing pattern (flag) used to begin and end the frame
- The bit insertion and deletion process used to provide code independence and data transparency
- The frame-check-sequence polynomial and algorithm
- The order of bit transmission.

- **ISO International Standard (IS) 4335 and (IS) 4335/DAD1, Data Communications—High-Level Data Link Control Procedures—Consolidation of Elements of Procedure (1984)**

This standard specifies the overall functional capabilities defined for HDLC within the frame structure standard. It defines possible operational modes and specifies the definition and encoding of the link level commands and responses that may be used in the control field of the frame. Protocols to be observed in the use of the commands and responses are described and illustrated by sequence diagrams of typical operational examples. This standard represents the superset or "menu" of HDLC functions that are

available. It does not discuss how this superset may be limited in specific modes of operation, applications, or configurations.

- **ISO International Standard (IS) 7809, HDLC Consolidation of Classes of Procedures (1984)**

This standard specifies and describes the class of procedure applicable for centralized data link control of point-to-point and multipoint configurations for both (1) Normal and Asynchronous Response Modes of operation and (2) Asynchronous Balanced Mode class of procedure applicable for peer-to-peer interchange in a point-to-point configuration. It provides the subset of HDLC functions (commands and responses) that are mandatory and those that are optional.

As noted earlier, standards give implementers considerable latitude in the choice of functional options and alternative configurations. This freedom may result in incompatibilities between different products that individually conform to HDLC. The following two examples illustrate how incompatibilities might occur.

Example 1: HDLC permits any number of bits in the information field of an Information command or response frame; SDLC permits any number of 8-bit bytes. Thus SDLC is a subset of HDLC. However, the XYZ Corporation could choose 13-bit characters, which is also an allowable subset of HDLC. Yet one set of products expects the messages to consist of $8n$ bits; the other, $13n$ bits. Usually, when information received does not conform to an expected bit length, a "transmission error" or an "improper information field" status would be indicated by the receiver. So, in this case, while both products are in conformance with HDLC, they would be incompatible.

Example 2: HDLC also provides a number of optional functional extensions for special application considerations or performance improvement. IBM SDLC products, in general, incorporate one or more of these functional extensions. However, if two products do not have the same functional subset, effective and productive communications between the two may not be possible. When an IBM SDLC product receives a transmission that is undefined for that product, an exception condition results.

The judgment that SDLC is in conformance with ISO HDLC is also based on the following:

- SDLC complies with **IS 3309, Frame Structure**, for information fields with an integral number of 8-bit bytes.
- SDLC commands and responses (that is, Elements of Procedure) that have corresponding HDLC counterparts comply with the ISO HDLC definitions and protocols as specified in **IS 4335**.
- Announced IBM SDLC products conform to the Unbalanced Normal (UN) Class of Procedure as specified in **IS 7809** and the Normal Disconnected Mode (NDM) as specified in **IS 4335**. These IBM SDLC products provide the required basic (minimum) command and response repertoire, and particular products provide one or more of the available optional functions. Unbalanced Normal operation with Normal Disconnected

Mode is the only class of procedure currently used in IBM SDLC products.

Figure 32 lists the basic command and response requirements for the ISO Unbalanced Normal Class of Procedures (**IS 7809**) as well as the commands and responses available for optional functional extensions.

Figure 33 contains the names of the commands and responses corresponding to the HDLC acronyms appearing in Figure 32. (The SDLC acronyms are the same.) This figure also shows the former HDLC/SDLC acronyms and command/response names that may appear in earlier documentation on HDLC and SDLC.

All IBM SDLC products implement the basic repertoire of commands and responses of the Unbalanced Normal (UN) class. In addition, specific IBM SDLC products may support one or more of the available optional functions. For instance, particular IBM SDLC products support one or more of the following optional functions:

- 1 (XID-XID/RD)
- 2 (REJ-REJ)
- 5 (SIM-RIM)

IBM SDLC does contain additional commands and responses not in the ISO Elements of Procedure (or addenda).

Note: SDLC includes the Configure (CFGR) command and CFGR and Beacon (BCN) responses for application in loop configurations only. ISO HDLC does not include loop operation.

Some IBM SDLC products do not allow the use of the Request Disconnect (RD) response (this response is a recent addition to the ISO Elements of Procedure). The REJ command and response are used only in those IBM SDLC products that provide two-way simultaneous information interchange. To determine the SDLC capabilities and characteristics of a specific IBM product, refer to the appropriate publications for that product.

Note: National and international standards, approved and proposed, are subject to continual review, modification, and enhancement. Any resulting changes, although they appear unlikely at this time, may alter IBM's judgment on SDLC conformance as stated in the preceding, which is based on the level of ISO HDLC documentation existing as of 1984.

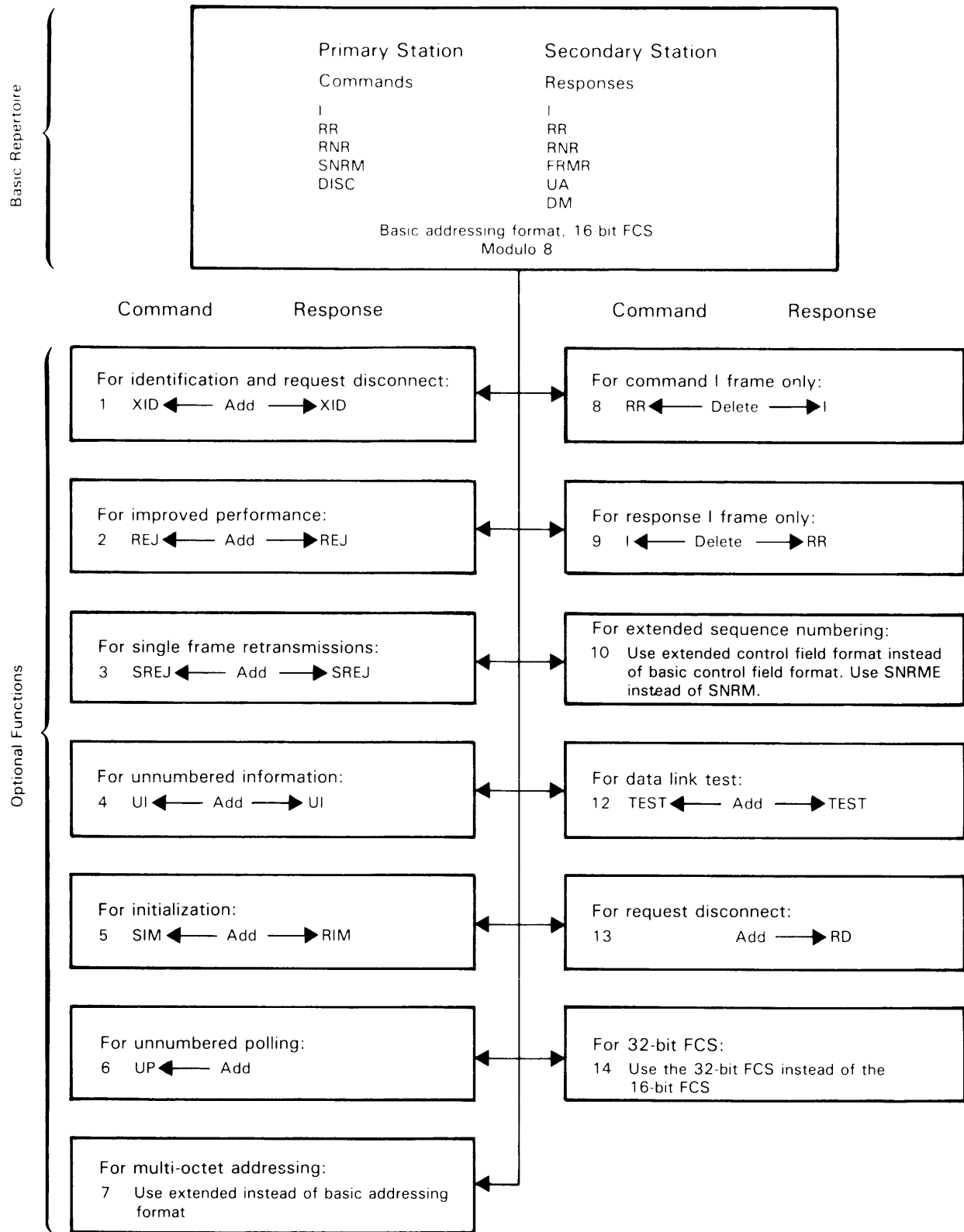

Figure 32. HDLC Unbalanced Normal Class of Procedures

Present Acronym	Present Name	Former Acronym	Former Name	Command	Response
				X	X
I	Information frame			X	X
RR	Receive Ready			X	X
RNR	Receive Not Ready			X	X
REJ	Reject			X	
SNRM	Set Normal Response Mode			X	
SIM	Set Initialization Mode			X	
DISC	Disconnect			X	X
XID	Exchange Identification			X	X
UI	Unnumbered Information	NSI	Nonsequenced Information	X	
UP	Unnumbered Poll	NSP	Nonsequenced Poll		X
UA	Unnumbered Acknowledge	NSA	Nonsequenced Acknowledge		X
DM	Disconnected Mode	ROL	Request Online		X
FRMR	Frame Reject	CMDR	Command Reject		X
RIM	Request Initialization Mode	RQI	Request Initialization Mode		X
RD	Request Disconnect	RQD	Request Disconnect		

Figure 33. HDLC Commands and Responses

Abbreviations
Glossary
Index

Contents

List of Abbreviations 77
Glossary 79
Index 83

List of Abbreviations

A	address (field)	NRM	normal response mode
BC	block check (field)	NRME	normal response mode extended
BCN	beacon	NRZI	nonreturn-to-zero inverted (zero-complementing differential coding)
C	control (field)	Ns	send count (transmitter's sequence number)
CFGR	configure	ORP	optional response poll
CRC	cyclic redundancy check	P/F	poll/final bit
DCE	data circuit-terminating equipment	RD	request disconnect
DISC	disconnect (command)	REJ	reject
DM	disconnect mode	RIM	request initialization mode
DTE	data terminal equipment	RNR	receive not ready (busy)
F	flag (pattern or field) or final (bit)	RR	receive ready
FCS	frame check sequence	S	supervisory (field, frame, or C-field format)
FRMR	frame reject	SDLC	synchronous data link control
HDLC	High-level Data Link Control	SIM	set initialization mode
I	information (frame or C-field format)	SNRM	set normal response mode
ISO	International Organization for Standardization	SNRME	set normal response mode extended
LS	link station	U	unnumbered (field, frame, or C-field format)
MRP	mandatory response poll	UA	unnumbered acknowledgment
ms	millisecond	UI	unnumbered information
NDM	normal disconnected mode	UP	unnumbered poll
Nr	receive count (next sequence number expected to receive)	XID	exchange station identification

Glossary

This glossary contains terms and definitions related to Synchronous Data Link Control (SDLC), and includes terms and definitions from these sources:

- The *IBM Vocabulary for Data Processing, Telecommunications, and Office Systems*, GC20-1699.
- The *American National Dictionary for Information Processing*, published by the Computer and Business Equipment Manufacturers Association. These definitions are identified by an asterisk (*) preceding the definition.
- The *ISO Vocabulary of Information Processing*, developed by the International Organization for Standardization. Technical Committee 97, Subcommittee 1. A definition preceded by the symbol "(ISO)" is reproduced from a published section of that document. A definition preceded by the symbol (TC97) indicates that the definition is reproduced from a working document, draft proposal, or draft international standard of ISO Technical Committee 97, Subcommittee 1 (Vocabulary) and that final agreement has not yet been reached among its participating members.

Some definitions are marked by both "*" and "(ISO)."

B

buffer. An area of storage that is temporarily reserved for use in performing an input/output operation, into which data is read or from which data is written.

C

carrier. A continuous frequency capable of being modulated or impressed with a second (information-carrying) signal.

channel. A communication path between stations.

command. (1) The control information (in the C-field of the link header) sent from the primary

station to the secondary station; (2) the entire frame so sent.

communication common carrier. In the USA and Canada, a public data transmission service that provides the general public with transmission service facilities; for example, a telephone or telegraph company.

confirmation. A type of response by a receiver that permits a sender to continue.

D

data. *Any representations such as characters or analog quantities to which meaning is, or might be, assigned.

data circuit. (1) (ISO) A pair of associated transmit and receive channels that provide a means of two-way data communication. (2) In SNA, synonym for link connection.

data circuit-terminating equipment (DCE). (ISO) In a data station, the equipment that provides the signal conversion and coding between the data terminal equipment (DTE) and the line.

Note: The DCE may be separate equipment or an integral part of the DTE or of the intermediate equipment.

data link. In SNA, the combination of the link connection and the link stations joining two adjacent network nodes; for example, a System/370 channel and its associated protocols, a serial-by-bit connection under the control of synchronous data link control (SDLC).

data station. * (ISO) The data terminal equipment (DTE), the data circuit-terminating equipment (DCE), and any intermediate equipment.

data switching exchange (DSE). (ISO) The equipment installed at a single location to provide switching functions, such as circuit switching, message switching, and packet switching.

data terminal equipment (DTE). * (ISO) That part of a data station that serves as a data source, data sink, or both.

F

frame. See SDLC transmission frame.

I

information. * (ISO) The meaning that a human being assigns to data by means of the conventions applied to that data.

invert on zero coding. A transmission coding method in which the DTE (data terminal equipment) changes the signal to the opposite state to send a binary 0 and leaves it in the same state to send a binary 1.

L

link. Synonym for data link.

link connection. In SNA, the physical equipment providing two-way communication between one link station and one or more other link stations; for example, a telecommunication line and data circuit-terminating equipment (DCE). A link connection, such as a multipoint, loop, or token-ring configuration, can be shared among multiple, logically distinct links.

link station. The combination of hardware and software that allows a node to attach to and provide control for a link.

N

node. An endpoint of a link or a junction common to two or more links in a network. Nodes can be host processors, communication controllers, cluster controllers, or terminals. Nodes can vary in routing and other functional capabilities.

numbered frames. Information segments arranged in numerical order for accountability.

P

polling. * Interrogation of devices for purposes such as to avoid contention, to determine operational status, or to determine readiness to send or receive data.

primary link station. The link station on a link that is responsible for the control of that link.

propagation delay. The time necessary for a signal to travel through a conductive medium from one point to another.

R

response. (1) The control information (in the C-field of the link header) sent from the secondary station to the primary station; (2) the entire frame so sent.

S

SDLC transmission frame. The vehicle for every command, every response, and all information that is transmitted using SDLC procedures. Each frame begins and ends with a flag. Synonymous with basic link unit.

secondary link station. The link station on a link, using a primary-secondary protocol, that is subordinate, in terms of control, to the primary link station.

simplex transmission. * (ISO) Data transmission in one preassigned direction only.

station. See link station.

synchronous. (1) * (ISO) Pertaining to two or more processes that depend upon the occurrences of a specific event such as a common timing signal. (2) Occurring with a regular or predictable time relationship.

Synchronous Data Link Control (SDLC). A discipline conforming to subsets of the Advanced Data Communication Control Procedures (ADCCP) of the American National Standards Institute (ANSI) and High-level Data Link Control (HDLC) of the International Standards Organization (ISO), for managing synchronous, code-transparent, serial-by-bit information transfer over a link connection. Transmission exchanges may be duplex or half-duplex over switched or nonswitched links. The configuration of the link connection may be point-to-point, multipoint, or loop.

T

telecommunication facility. Transmission capabilities, or the means for providing such capabilities, made available by a communication common carrier or by a telecommunication administration.

time out. (1) (ISO) An event that occurs at the end of a predetermined period of time that began at the occurrence of another specified event. (2) A time interval allotted for certain operations to occur; for example, response to polling or addressing before system operation is interrupted and must be restarted.

transmission frame. See SDLC transmission frame.

transmission medium. (TC97) Any material substance that can be, or is, used for the propagation of signals, usually in the form of modulated radio, light, or acoustic waves, from one point to another,

such as an optical fiber, cable, bundle, wire, dielectric slab, water, or air.

Note: Free space can also be considered as a transmission medium for electromagnetic waves.

transparent. In data transmission, pertaining to information that is not recognized by the receiving program or device as transmission control characters.

turnaround. The reversal of the direction of transmission from send to receive or from receive to send; usually used in reference to a half-duplex communication channel.

Index

A

abort 30, 31
 pattern 30
active state 21
address (A) field 23, 43, 51
address, broadcast 24, 43
address, common 24
address, group 24, 43
address, station 24, 43

B

Beacon (BCN) response 49
Beacon Test subcommand 48
bit stuffing 27
bit synchronization 12, 14
broadcast address 24, 43
buffer overrun 12
busy station 31, 32

C

carrier off 20
channel, communication 4
 configurations
 See link connection, configurations
character synchronization 12
circuit, data 4
Clear subcommand 47
clear-to-send time (delay) 29
CMDR (Command Reject) 40
 See also unnumbered (U) commands and responses, FRMR (Frame Reject)
command reject 40
commands and responses, supervisory (S)
 REJ (Reject) 41
 RNR (Receive Not Ready) 41
 RR (Receive Ready) 41
commands and responses, unnumbered (U) 38
 BCN (Beacon) 49
 CFGR (Configure) 47, 49
 DISC (Disconnect) 39
 DM (Disconnected Mode) 39
 FRMR (Frame Reject) 40
 RD (Request Disconnect) 39
 RIM (Request Initialization Mode) 39
 SIM (Set Initialization Mode) 39
 SNRM (Set Normal Response Mode) 39

SNRME (Set Normal Response Mode Extended) 39
TEST (Test) 40
UA (Unnumbered Acknowledgment) 39
UI (Unnumbered Information) 39
UP (Unnumbered Poll) 46
XID (Exchange Station Identification) 40, 42
commands, SDLC
 definitions of 36
 rejection of 32
common address 24
communication channel 4
 configurations
 See link connection, configurations
Configure (CFGR) command 49
Configure (CFGR) response 47
confirm, confirmation 25, 26, 46
 and REJ frame 41
 and RR frame 41
control (C) field 24, 38, 51
conversion, data 10
CRC (cyclic redundancy check) 26, 31
 computation of 65
CRC error 3, 26, 31
cycle, command and response 45

D

data circuit 4
data circuit-terminating equipment (DCE) 3, 6, 10
data conversion 10
data link
 components of 3, 4
 configurations
 See link connection, configurations
data link control
 activities 12
 examples 51
data link, states of a
 See transmission states
data terminal equipment (DTE) 3, 10, 14
DCE (data circuit-terminating equipment) 3, 6, 10
deserialization 10
Disconnect (DISC) command 39
disconnect, disconnected 25, 39
 and DISC command 36, 39
 and DM response 39
 and RD response 39
 mode 35
 secondary station 36
Disconnected Mode (DM) response 39
DTE (data terminal equipment) 3, 10, 14
duplex 6, 21
duplex multipoint operation 9

E

error recovery 31
error, CRC 3, 26, 31
error, transmission 3, 26, 31
examples
 loop 58
 multipoint 56
 nonswitched point-to-point 52, 54
 switched point-to-point 57
Exchange Station Identification (XID) command 40, 42
Exchange Station Identification (XID) response 40, 42

F

F (final) bit 25, 41
F (flag) 23
FCS (frame check sequence) 26
 computation of 65
field, address (A) 23, 43, 51
field, control (C) 24, 38, 51
field, FCS 26
 computation of 65
field, information 25
 of FRMR response 40
flag 23
format
 See also supervisory (S) commands and responses
 See also unnumbered (U) commands and responses
 control (C) field
 See control (C) field
 information (I) 25
 supervisory (S) 25
 unnumbered (U) 25
frame 21
 See also Nr (receiver frame count)
 See also Ns (transmitter frame count)
 format of 22, 63
 functions of 21
 information (I) 25, 27, 42
 and disconnected mode 39
 and Nr/Ns counts 26
 outstanding 26
 pending 47
 invalid 40
 number, numbering 25, 26, 27
 summary 63
 supervisory (S) 25, 41
 and disconnected mode 39
 unnumbered (U) 25, 38
frame check sequence (FCS) 26
 computation of 65

Frame Reject (FRMR) response 40
frames, numbered 25, 27
 and Ns count 26
 and REJ frame 41
 and RNR frame 41

G

generating polynomial, CRC 65
go-ahead sequence 43, 44
group address 24, 43

H

half-duplex 6
HDLC, relationship of SDLC to 69
higher-level recovery 31, 32

I

idle
 detect time out 29
 inactivity time out 42
 pattern 20
idle state 20, 29, 30
information (I) format 42
information (I) frame 42
information field 25
 of FRMR response 40
initialization 27, 35, 39
initialization mode 35
intervention 32
invalid frame 40
invert-on-zero coding 14, 15, 28

L

link connection 4
 configurations 4, 5, 29
 loop 3, 9
 nonswitched multipoint 3, 5, 6
 nonswitched point-to-point 3, 5, 6
 switched point-to-point 3, 6
link station 3, 19
 primary 6, 19, 28
 on loop 43
 on switched link 42
 secondary 6, 19
 modes 35, 36
 on loop 44

- on switched link 42
 - switched 42
- link-level recovery 31
- loop configuration, SDLC in a 42
- loop operation 43
- loop, SDLC
 - commands 46
 - configuration 43
 - exception conditions 47
 - polling on 46
 - primary link station 43
 - responses 49
 - secondary link station 44
 - transmission on 44, 45, 58

M

- mandatory response poll 47
- mode, initialization 35
- Modified Link Test subcommand 48
- modulo-128 operation 36, 39
 - and normal response mode extended 35
 - and Nr/Ns counts 26
- modulo-8 operation 27, 36, 39
 - and normal response mode 35
 - and Nr/Ns counts 26
- Monitor Mode subcommand 48

N

- NDM (normal disconnected mode) 36
- nonproductive receive condition/time out 30
- normal disconnected mode (NDM) 36
- normal response mode (NRM) 35, 40
- normal response mode extended (NRME) 35
- Nr (receiver frame count) 26, 27, 31
 - and I frames 42
 - and REJ frames 41
 - and RNR frames 41
 - and RR frames 41
 - and S frames 41
 - and U frames 38
 - C field bits for 35
 - invalid 40, 47
 - purpose of 25
 - resetting 39
- NRM (normal response mode) 35, 40
- NRME (normal response mode extended) 35
- NRZI (non-return-to-zero inverted) 14
- Ns (transmitter frame count) 26, 27
 - and I frames 42
 - and U frames 38
 - C field bits for 35
 - purpose of 25
 - resetting 39

- NSA (Nonsequenced Acknowledgment)
 - See unnumbered (U) commands and responses, UA (Unnumbered Acknowledgment)
- NSI (Nonsequenced Information)
 - See unnumbered (U) commands and responses, UI (Unnumbered Information)
- NSP (Nonsequenced Poll)
 - See unnumbered (U) commands and responses, UP (Unnumbered Poll)
- numbered frames 25, 27
 - and Ns count 26
 - and REJ frame 41
 - and RNR frame 41

O

- offline 25, 39
 - and DISC command 36, 39
 - and DM response 39
 - and RD response 39
 - mode 35
 - secondary station 36
- online 32
- overrun, buffer 12

P

- P (poll) bit 25, 29, 35
 - in UP command 46, 47
- P/F (poll/final) bit
 - See F (final) bit
 - See P (poll) bit
- poll, polling 25, 35, 46
 - response to 32
- polynomial, generating, (CRC) 65
- prerequisite publication iii
- primary link station
 - See link station, primary
- propagation time (delay) 29

R

- Receive Not Ready (RNR) command 41
- Receive Not Ready (RNR) response 41
- Receive Ready (RR) command 41
- Receive Ready (RR) response 41
- received-data timing 14
- recover, recovery situation 29, 31, 32
 - and nonproductive receive condition 30
- Reject (REJ) command 41
- Reject (REJ) response 41
- reject, frame 40

- repeater 43
- Request Disconnect (RD) response 39
- Request Initialization Mode (RIM) response 39
- response mode, normal 35, 40
- responses
 - See also supervisory (S) commands and responses
 - See also unnumbered (U) commands and responses
 - definitions of 36
- retransmissions 27, 31, 41
 - counting of 32
- ROL (Request Online)
 - See unnumbered (U) commands and responses, DM (Disconnected Mode)
- RQI (Request Initialization)
 - See unnumbered (U) commands and responses, RIM (Request Initialization Mode)

S

- sample time, timing 14, 15
- SDLC exchanges, examples of 51
- SDLC frame 21
 - format of 22, 63
 - functions of 21
 - information (I) 25, 27, 42
 - and disconnected mode 39
 - and Nr/Ns counts 26
 - outstanding 26
 - pending 47
 - invalid 40
 - number, numbering 25, 26, 27
 - summary 63
 - supervisory (S) 25, 41
 - and disconnected mode 39
 - unnumbered (U) 25, 38
- SDLC loop
 - commands 46
 - configuration 43
 - exception conditions 47
 - polling on 46
 - primary link station 43
 - responses 49
 - secondary link station 44
 - transmission on 44, 45, 58
- SDLC, relationship of HDLC to 69
- secondary link station
 - See link station, secondary
- Self-Test subcommand 48, 49
- serialization 10
- Set Initialization Mode (SIM) command 39
- Set Normal Response Mode (SNRM) command 39
- Set Normal Response Mode Extended (SNRME) command 39
- shutoff sequence 45
- signal conversion 4, 10
- simplex transmission 9
- state, active 21

- state, idle 20, 29, 30
- state, transient 19
- states, transmission 19
- station
 - See link station
- station address 24, 43
- supervisory (S) commands and responses
 - REJ (Reject) 41
 - RNR (Receive Not Ready) 41
 - RR (Receive Ready) 41
- supervisory (S) format 41
 - See also supervisory (S) commands and responses
- supervisory (S) frame 41
 - See also supervisory (S) commands and responses
- switched link station
 - See link station, switched
- switched link, SDLC on a 42
- synchronization, bit 12, 14
- synchronization, character 12

T

- telecommunication facilities, examples of 29
- Test (TEST) command 40
- Test (TEST) response 40
- time out 28, 35, 42
 - idle detect 29
 - nonproductive receive 30
- time, sample 14, 15
- timing, received-data 14
- timing, sample 14, 15
- transient state 19
- transmission error 3, 26, 31
- transmission exchanges, examples of 51
- transmission frame 21
 - format of 22, 63
 - functions of 21
 - information (I) 25, 27, 42
 - and disconnected mode 39
 - and Nr/Ns counts 26
 - outstanding 26
 - pending 47
 - invalid 40
 - number, numbering 25, 26, 27
 - summary 63
 - supervisory (S) 25, 41
 - and disconnected mode 39
 - unnumbered (U) 25, 38
- transmission medium 3, 4
- transmission states 19
- turnaround 19, 43, 45
- two-way alternate transmission 3, 7, 29
 - on point-to-point link 52
 - on switched link 57
- two-way simultaneous transmission 3, 7
 - on multipoint link 56
 - on point-to-point link 54

U

unnumbered (U) commands and responses 38
BCN (Beacon) 49
CFGR (Configure) 47, 49
DISC (Disconnect) 39
DM (Disconnected Mode) 39
FRMR (Frame Reject) 40
RD (Request Disconnect) 39
RIM (Request Initialization Mode) 39
SIM (Set Initialization Mode) 39
SNRM (Set Normal Response Mode) 39
SNRME (Set Normal Response Mode
Extended) 39
TEST (Test) 40
UA (Unnumbered Acknowledgment) 39
UI (Unnumbered Information) 39
UP (Unnumbered Poll) 46
XID (Exchange Station Identification) 40, 42
unnumbered (U) format 38

See also unnumbered (U) commands and
responses

unnumbered (U) frame 38

See also unnumbered (U) commands and
responses

Unnumbered Acknowledgment (UA) response 39

Unnumbered Information (UI) command 39

Unnumbered Information (UI) response 39

Unnumbered Poll (UP) command 46

W

Wrap subcommand 48

Z

zero insertion 14, 27, 28

and unintentional aborting 30

Concepts

Publication No. GA27-3093-3

This manual is part of a library that serves as a reference source for systems analysts, programmers, and operators of IBM systems. You may use this form to communicate your comments about this publication, its organization, or subject matter, with the understanding that IBM may use or distribute whatever information you supply in any way it believes appropriate without incurring any obligation to you.

Note: Copies of IBM publications are not stocked at the location to which this form is addressed. Please direct any requests for copies of publications, or for assistance in using your IBM system, to your IBM representative or to the IBM branch office serving your locality.

Possible topics for comment are:

Clarity Accuracy Completeness Organization Coding Retrieval Legibility

If you wish a reply, give your name, company, mailing address, and date:

What is your occupation? _____

Number of latest Newsletter associated with this publication: _____

Thank you for your cooperation. No postage stamp necessary if mailed in the U.S.A. (Elsewhere, an IBM office or representative will be happy to forward your comments or you may mail directly to the address in the Edition Notice on the back of the title page.)

Reader's Comment Form

Fold and tape

Please Do Not Staple

Fold and tape



NO POSTAGE
NECESSARY
IF MAILED
IN THE
UNITED STATES

BUSINESS REPLY MAIL

FIRST CLASS PERMIT NO. 40 ARMONK, N.Y.

POSTAGE WILL BE PAID BY ADDRESSEE

International Business Machines Corporation
Dept. E02
P.O. Box 12195
Research Triangle Park, N.C. 27709-9990

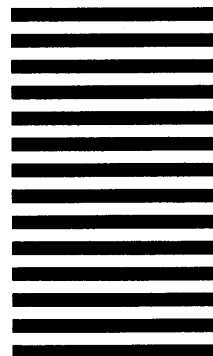

Fold and tape

Please Do Not Staple

Fold and tape



File No. GENL-30 (SNA)

GA27-3093-3

Printed in USA.

GA27-3093-03

